

United Capital Group

ENERGY L.L.C



PRODUCT CATALOGUE (MANUFACTURER OF PIPE FITTINGS)



- ▲ **Weld Neck Flange**
- ▲ **Threaded Flange**
- ▲ **Slip On Flange**
- ▲ **Lap Joint Flange**
- ▲ **Socket Weld Flange**
- ▲ **Blind Flange**

ANSI B16.5 Class 150 Flanges

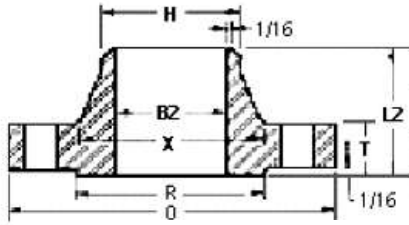

Weld Neck Flange

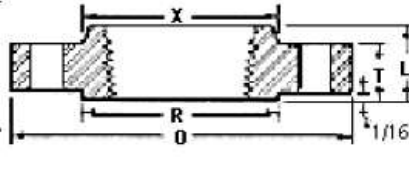

Threaded Flange

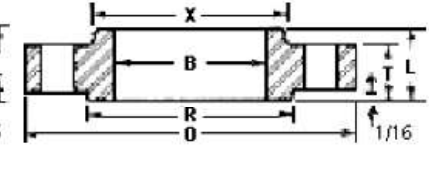

Slip On Flange

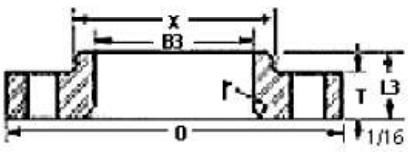

Lap Joint Flange

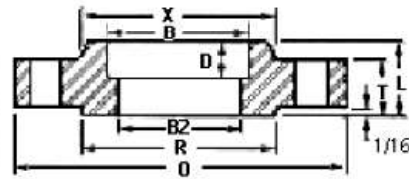

Socket Weld Flange

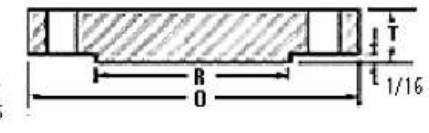

Blind Flange

Nom. Pipe Size	O	T	R	X	No./Dia. of Holes	Bolt Circle Dia.	L2	H	B2	L	B	r	L3	B3	D
1/2	3.50	0.44	1.38	1.19	4-0.62	2.38	1.88	0.84	0.62	0.62	0.88	0.12	0.62	0.90	0.38
3/4	3.88	0.50	1.69	1.50	4-0.62	2.75	2.06	1.05	0.82	0.62	1.09	0.12	0.62	1.11	0.44
1	4.25	0.56	2.00	1.94	4-0.62	3.12	2.19	1.32	1.05	0.69	1.36	0.12	0.69	1.38	0.50
1-1/4	4.62	0.62	2.50	2.31	4-0.62	3.50	2.25	1.66	1.38	0.81	1.70	0.19	0.81	1.72	0.56
1-1/2	5.00	0.68	2.88	2.56	4-0.62	3.88	2.44	1.90	1.61	0.88	1.95	0.25	0.88	1.97	0.62
2	6.00	0.75	3.62	3.06	4-0.75	4.75	2.50	2.38	2.07	1.00	2.44	0.31	1.00	2.46	0.69
2-1/2	7.00	0.88	4.12	3.56	4-0.75	5.50	2.75	2.88	2.47	1.12	2.94	0.31	1.12	2.97	0.75
3	7.50	0.94	5.00	4.25	4-0.75	6.00	2.75	3.50	3.07	1.19	3.57	0.38	1.19	3.60	0.81
3-1/2	8.50	0.94	5.50	4.81	8-0.75	7.00	2.81	4.00	3.55	1.25	4.07	0.38	1.25	4.10	0.88
4	9.00	0.94	6.19	5.31	8-0.75	7.50	3.00	4.50	4.03	1.31	4.57	0.44	1.31	4.60	0.94
5	10.00	0.94	7.31	6.44	8-0.88	8.50	3.50	5.56	5.05	1.44	5.66	0.44	1.44	5.69	0.94
6	11.00	1.00	8.50	7.56	8-0.88	9.50	3.50	6.63	6.07	1.56	6.72	0.50	1.56	6.75	1.06
8	13.50	1.12	10.62	9.69	8-0.88	11.75	4.00	8.63	7.98	1.75	8.72	0.50	1.75	8.75	1.25
10	16.00	1.19	12.75	12.00	12-1.00	14.25	4.00	10.75	10.02	1.94	10.88	0.50	1.94	10.92	1.31
12	19.00	1.25	15.00	14.38	12-1.00	17.00	4.50	12.75	12.00	2.19	12.88	0.50	2.19	12.92	1.56
14	21.00	1.38	16.25	15.75	12-1.12	18.75	5.00	14.00	13.25	2.25	14.14	0.50	3.12	14.18	1.63
16	23.50	1.44	18.50	18.00	16-1.12	21.25	5.00	16.00	15.25	2.50	16.16	0.50	3.44	16.19	1.75
18	25.00	1.56	21.00	19.88	16-1.25	22.75	5.50	18.00	17.25	2.69	18.18	0.50	3.81	18.20	1.94
20	27.50	1.69	23.00	22.00	20-1.25	25.00	5.69	20.00	19.25	2.88	20.20	0.50	4.06	20.25	2.13
22	29.50	1.81	25.25	24.25	20-1.38	27.25	5.88	22.00	21.25	3.13	22.22	0.50	4.25	22.25	2.38
24	32.00	1.88	27.25	26.12	20-1.38	29.50	6.00	24.00	23.25	3.25	24.25	0.50	4.38	24.25	2.50

Dimensions in inches.

ANSI B16.5 Class 300 Flanges

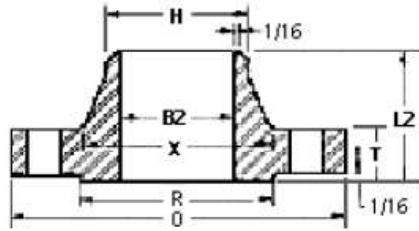

Weld Neck Flange

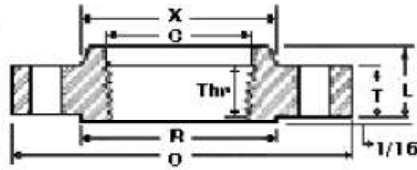

Threaded Flange

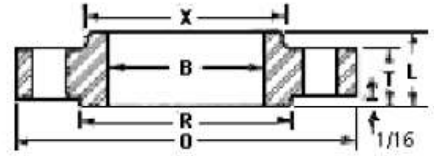

Slip On Flange

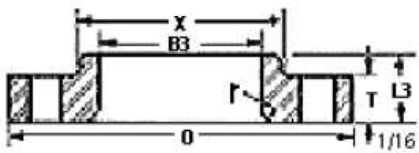

Lap Joint Flange

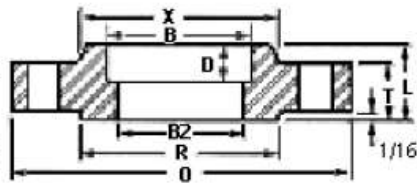

Socket Weld Flange

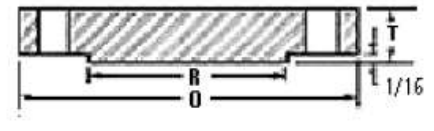

Blind Flange

Nom. Pipe Size	O	T	R	X	No. & Dia. of Holes	Bolt Circle Dia.	L2	H	B2	L	B	r	L3	B3	D	C	THr
1/2	3.75	0.56	1.38	1.5	4-0.62	2.62	2.06	0.84	0.62	0.88	0.88	0.12	0.88	0.90	0.38	0.93	0.62
3/4	4.62	0.62	1.69	1.88	4-0.75	3.25	2.25	1.05	0.82	1.00	1.09	0.12	1.00	1.11	0.44	1.14	0.62
1	4.88	0.69	2.00	2.12	4-0.75	3.50	2.44	1.32	1.05	1.06	1.36	0.12	1.06	1.38	0.50	1.41	0.69
1-1/4	5.25	0.75	2.50	2.50	4-0.75	3.88	2.56	1.66	1.38	1.06	1.70	0.19	1.06	1.72	0.56	1.75	0.81
1-1/2	6.12	0.81	2.88	2.75	4-0.88	4.50	2.69	1.90	1.61	1.19	1.95	0.25	1.19	1.97	0.62	1.99	0.88
2	6.50	0.88	3.62	3.31	8-0.75	5.00	2.75	2.38	2.07	1.31	2.44	0.31	1.31	2.46	0.69	2.50	1.12
2-1/2	7.50	1.00	4.12	3.94	8-0.88	5.88	3.00	2.88	2.47	1.50	2.94	0.31	1.50	2.97	0.75	3.00	1.25
3	8.25	1.12	5.00	4.62	8-0.88	6.62	3.12	3.50	3.07	1.69	3.57	0.38	1.69	3.60	0.81	3.63	1.25
3-1/2	9.00	1.19	5.50	5.25	8-0.88	7.25	3.19	4.00	3.55	1.75	4.07	0.38	1.75	4.10		4.13	1.44
4	10.00	1.25	6.19	5.75	8-0.88	7.88	3.38	4.50	4.03	1.88	4.57	0.44	1.88	4.60		4.63	1.44
5	11.00	1.38	7.31	7.00	8-0.88	9.25	3.88	5.56	5.05	2.00	5.66	0.44	2.00	5.69		5.69	1.69
6	12.50	1.44	8.50	8.12	12-0.88	10.62	3.88	6.63	6.07	2.06	6.72	0.50	2.06	6.75		6.75	1.81
8	15.00	1.62	10.62	10.25	12-1.00	13.00	4.38	8.63	7.98	2.44	8.72	0.50	2.44	8.75		8.75	2.00
10	17.50	1.88	12.75	12.62	16-1.12	15.25	4.62	10.75	10.02	2.62	10.88	0.50	3.75	10.92		10.88	2.19
12	20.50	2.00	15.00	14.75	16-1.25	17.75	5.12	12.75	12.00	2.88	12.88	0.50	4.00	12.92		12.94	2.38
14	23.00	2.12	16.25	16.75	20-1.25	20.25	5.62	14.00	13.25	3.00	14.14	0.50	4.38	14.18		14.19	2.50
16	25.50	2.25	18.50	19.00	20-1.38	22.50	5.75	16.00	15.25	3.25	16.16	0.50	4.75	16.19		16.19	2.69
18	28.00	2.38	21.00	21.00	24-1.38	24.75	6.25	18.00	17.25	3.50	18.18	0.50	5.12	18.20		18.19	2.75
20	30.50	2.50	23.00	23.12	24-1.38	27.00	6.38	20.00	19.25	3.75	20.20	0.50	5.50	20.25		20.19	2.88
22	33.00	2.63	25.25	25.25	24-1.63	29.25	6.50	22.00	21.25	4.00	22.22	0.50	5.75	22.25		22.19	3.13
24	36.00	2.75	27.25	27.62	24-1.62	32.00	6.62	24.00	23.25	4.19	24.25	0.50	6.00	24.25		24.19	3.25

Dimensions in inches.

ANSI B16.5 Class 400 Flanges

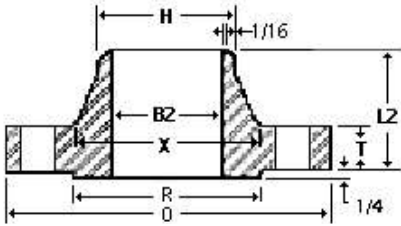

Weld Neck Flange

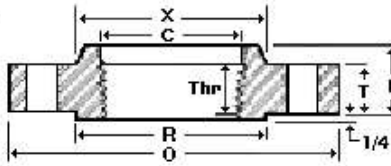

Threaded Flange

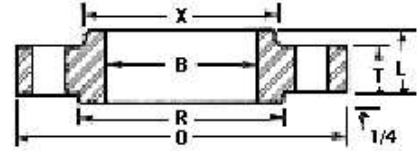

Slip On Flange

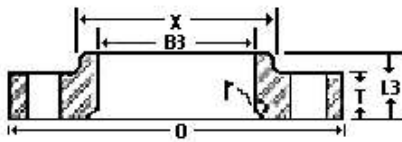

Lap Joint Flange

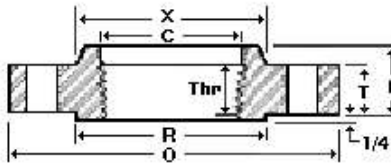

Socket Weld Flange

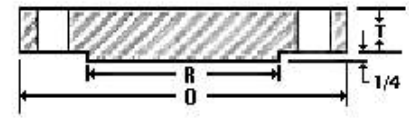

Blind Flange

Nom. Pipe Size	O	T	R	X	No. & Dia. of Holes	Bolt Circle Dia.	L2	H	B2	L	B	r	L3	B3	D	C	Thr
1/2	3.75	0.56	1.38	1.50	4-0.62	2.62	2.06	0.84	To be specified by purchaser.	0.88	0.88	0.12	0.88	0.90	0.38	0.93	0.62
3/4	4.62	0.62	1.69	1.88	4-0.75	3.25	2.25	1.05		1.00	1.09	0.12	1.00	1.11	0.44	1.14	0.62
1	4.88	0.69	2.00	2.12	4-0.75	3.50	2.44	1.32		1.06	1.36	0.12	1.06	1.38	0.50	1.41	0.69
1-1/4	5.25	0.81	2.50	2.50	4-0.75	3.88	2.62	1.66		1.12	1.70	0.19	1.12	1.72	0.56	1.75	0.81
1-1/2	6.12	0.88	2.88	2.75	4-0.88	4.50	2.75	1.90		1.25	1.95	0.25	1.25	1.97	0.62	1.99	0.88
2	6.50	1.00	3.62	3.31	8-0.75	5.00	2.88	2.38		1.44	2.44	0.31	1.44	2.46	0.69	2.50	1.12
2-1/2	7.50	1.12	4.12	3.94	8-0.88	5.88	3.12	2.88		1.62	2.94	0.31	1.62	2.97	0.75	3.00	1.25
3	8.25	1.25	5.00	4.62	8-0.88	6.62	3.25	3.50		1.81	3.57	0.38	1.81	3.60	0.81	3.63	1.38
3-1/2	9.00	1.38	5.50	5.25	8-1.00	7.25	3.38	4.00		1.94	4.07	0.38	1.94	4.10		4.13	1.56
4	10.00	1.38	6.19	5.75	8-1.00	7.88	3.50	4.50		2.00	4.57	0.44	2.00	4.60		4.63	1.44
5	11.00	1.50	7.31	7.00	8-1.00	9.25	4.00	5.56		2.12	5.66	0.44	2.12	5.69		5.69	1.69
6	12.5	1.62	8.50	8.12	12-1.00	10.62	4.06	6.63		2.25	6.72	0.50	2.25	6.75		6.75	1.81
8	15.00	1.88	10.62	10.25	12-1.12	13.00	4.62	8.63		2.69	8.72	0.50	2.69	8.75		8.75	2.00
10	17.5	2.12	12.75	12.62	16-1.25	15.25	4.88	10.75		2.88	10.88	0.50	4.00	10.92		10.88	2.19
12	20.5	2.25	15.00	14.75	16-1.38	17.75	5.38	12.75		3.12	12.88	0.50	4.25	12.92		12.94	2.38
14	23.00	2.38	16.25	16.75	20-1.38	20.25	5.88	14.00		3.31	14.14	0.50	4.62	14.18		14.19	2.50
16	25.5	2.50	18.50	19.00	20-1.50	22.50	6.00	16.00		3.69	16.16	0.50	5.00	16.19		16.19	2.69
18	28.00	2.62	21.00	21.00	24-1.50	24.75	6.50	18.00		3.88	18.18	0.50	5.38	18.20		18.19	2.75
20	30.5	2.75	23.00	23.12	24-1.62	27.00	6.62	20.00		4.00	20.20	0.50	5.75	20.25		20.19	2.88
22	33.00	2.88	25.25	25.25	24-1.75	29.25	6.75	22.00		4.25	22.22	0.50	6.00	22.25		--	--
24	36.00	3.00	27.25	27.62	24-1.88	32.00	6.88	24.00		4.50	24.25	0.50	6.25	24.25		24.19	3.25

Dimensions in inches.

1. Sizes NPS 1/2 through 3-1/2 are same as Class 600 flanges.

2. 1/4 in. raised face not included in dimensions T, L and L2.

3. Bolt hole diameter 1/8 in. larger than bolt diameter.

ANSI B16.5 Class 600 Flanges

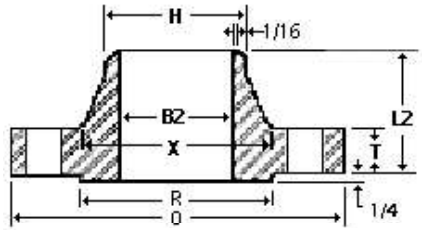

Weld Neck Flange

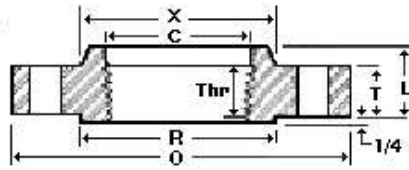

Threaded Flange

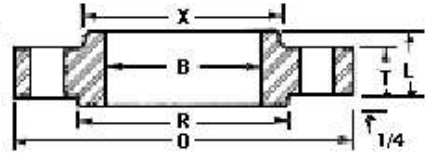

Slip On Flange

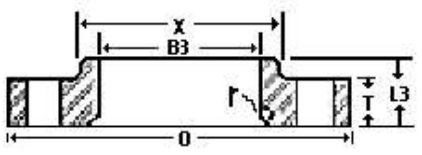

Lap Joint Flange

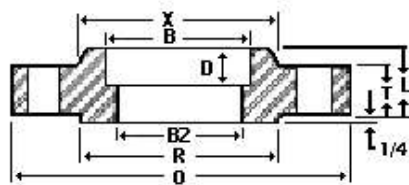

Socket Weld Flange

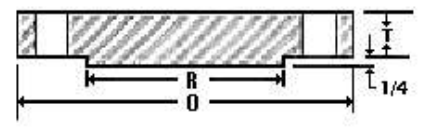

Blind Flange

Nom. Pipe Size	O	T	R	X	No. & Dia. of Holes	Bolt Circle Dia.	L2	H	B2	L	B	r	L3	B3	D	C	Thr
1/2	3.75	0.56	1.38	1.50	4-0.62	2.62	2.06	0.84	To be specified by purchaser.	0.88	0.88	0.12	0.88	0.90	0.38	0.93	0.62
3/4	4.62	0.62	1.69	1.88	4-0.75	3.25	2.25	1.05		1.00	1.09	0.12	1.00	1.11	0.44	1.14	0.62
1	4.88	0.69	2.00	2.12	4-0.75	3.50	2.44	1.32		1.06	1.36	0.12	1.06	1.38	0.50	1.41	0.69
1-1/4	5.25	0.81	2.50	2.50	4-0.75	3.88	2.62	1.66		1.12	1.70	0.19	1.12	1.72	0.56	1.75	0.81
1-1/2	6.12	0.88	2.88	2.75	4-0.88	4.50	2.75	1.90		1.25	1.95	0.25	1.25	1.97	0.62	1.99	0.88
2	6.50	1.00	3.62	3.31	8-0.75	5.00	2.88	2.38		1.44	2.44	0.31	1.44	2.46	0.69	2.50	1.12
2-1/2	7.50	1.12	4.12	3.94	8-0.88	5.88	3.12	2.88		1.62	2.94	0.31	1.62	2.97	0.75	3.00	1.25
3	8.25	1.25	5.00	4.62	8-0.88	6.62	3.25	3.50		1.81	3.57	0.38	1.81	3.60	0.81	3.63	1.38
3-1/2	9.00	1.38	5.50	5.25	8-1.00	7.25	3.38	4.00		1.94	4.07	0.38	1.94	4.10		4.13	1.56
4	10.75	1.50	6.19	6.00	8-1.00	8.50	4.00	4.50		2.12	4.57	0.44	2.12	4.60		4.63	1.62
5	13.00	1.75	7.31	7.44	8-1.12	10.50	4.50	5.56		2.38	5.66	0.44	2.38	5.69		5.69	1.88
6	14.00	1.88	8.50	8.75	12-1.12	11.50	4.62	6.63		2.62	6.72	0.50	2.62	6.75		6.75	2.00
8	16.50	2.19	10.62	10.75	12-1.25	13.75	5.25	8.63		3.00	8.72	0.50	3.00	8.75		8.75	2.25
10	20.00	2.50	12.75	13.50	16-1.38	17.00	6.00	10.75		3.38	10.88	0.50	4.38	10.92		10.88	2.56
12	22.00	2.62	15.00	15.75	20-1.38	19.25	6.12	12.75		3.62	12.88	0.50	4.62	12.92		12.94	2.75
14	23.75	2.75	16.25	17.00	20-1.50	20.75	6.50	14.00		3.69	14.14	0.50	5.00	14.18		14.19	2.88
16	27.00	3.00	18.50	19.50	20-1.62	23.75	7.00	16.00		4.19	16.16	0.50	5.50	16.19		16.19	3.06
18	29.25	3.25	21.00	21.50	20-1.75	25.75	7.25	18.00		4.62	18.18	0.50	6.00	18.20		18.10	3.12
20	32.00	3.50	23.00	24.00	24-1.75	28.50	7.50	20.00		5.00	20.20	0.50	6.50	20.25		20.19	3.25
22	34.25	3.75	25.25	26.25	24-1.75	30.63	7.75	22.00		5.25	22.22	0.50	6.88	22.25		--	--
24	37.00	4.00	27.25	28.25	24-2.00	33.00	8.00	24.00		5.50	24.25	0.50	7.25	24.25		24.19	3.62

Dimensions in inches.

1. Sizes NPS 1/2 through 3-1/2 are same as Class 400 flanges.
2. 1/4 in. raised face not included in dimensions T, L and L2.
3. Bolt hole diameter 1/8 in. larger than bolt diameter.

ANSI B16.5 Class 900 Flanges

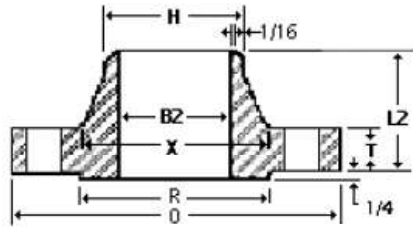

Weld Neck Flange

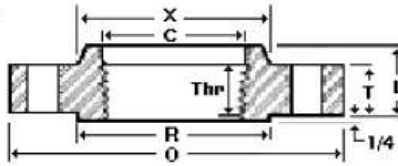

Threaded Flange

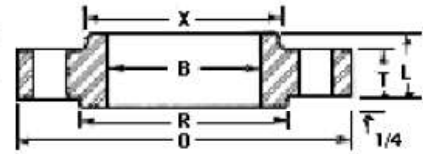

Slip On Flange

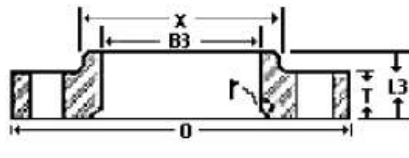

Lap Joint Flange

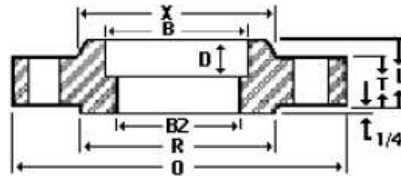

Socket Weld Flange

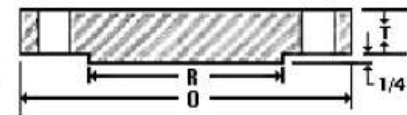

Blind Flange

Nom. Pipe Size	O	T	R	X	No. & Dia. of Holes	Bolt Circle Dia.	L2	H	B2	L	B	r	L3	B3	Thrd
Sizes 1/2" Thru 2-1/2" Are Identical To Class 1500.															
3	9.50	1.50	5.00	5.00	8-1.00	7.50	4.00	3.50	To be specified by purchaser.	2.13	3.57	0.38	2.13	3.60	1.63
4	11.50	1.75	6.19	6.25	8-1.25	9.25	4.50	4.50		2.75	4.57	0.44	2.75	4.60	1.88
5	13.75	2.00	7.31	7.50	8-1.38	11.00	5.00	5.56		3.13	5.66	0.44	3.13	5.69	2.13
6	15.00	2.19	8.50	9.25	12-1.25	12.50	5.50	6.63		3.38	6.72	0.50	3.38	6.75	2.25
8	18.50	2.50	10.63	11.75	12-1.50	15.50	6.38	8.63		4.00	8.72	0.50	4.50	8.75	2.50
10	21.50	2.75	12.75	14.50	16-1.50	18.50	7.25	10.75		4.25	10.88	0.50	5.00	10.92	2.81
12	24.00	3.13	15.00	16.50	20-1.50	21.00	7.88	12.75		4.63	12.88	0.50	5.63	12.92	3.00
14	25.25	3.38	16.25	17.75	20-1.63	22.00	8.38	14.00		5.13	14.14	0.50	6.13	14.18	3.25
16	27.75	3.50	18.50	20.00	20-1.75	24.25	8.50	16.00		5.25	16.16	0.50	6.50	16.19	3.38
18	31.00	4.00	21.00	22.25	20-2.00	27.00	9.00	18.00		6.00	18.18	0.50	7.50	18.20	3.50
20	33.75	4.25	23.00	24.50	20-2.13	29.50	9.75	20.00	6.25	20.20	0.50	8.25	20.25	3.63	
24	41.00	5.50	27.25	29.50	20-2.63	35.50	11.50	24.00	8.00	24.25	0.50	10.50	24.25	4.00	

Dimensions in inches.

1. Sizes NPS 1/2 through 2-1/2 are same as Class 1500 flanges.
2. 1/4 in. raised face not included in dimensions T, L and L2.
3. Bolt hole diameter 1/8 in. larger than bolt diameter.

ANSI B16.5 Class 1500 Flanges

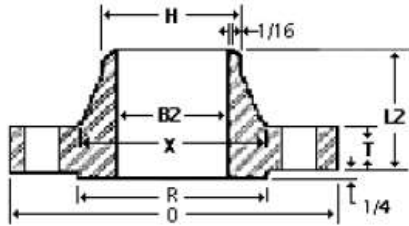

Weld Neck Flange

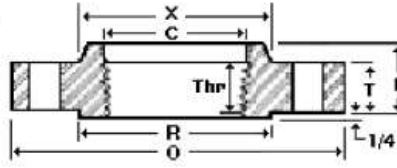

Threaded Flange

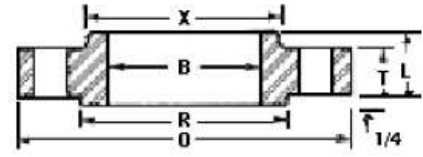

Slip On Flange

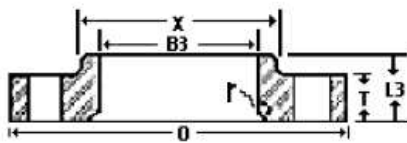

Lap Joint Flange

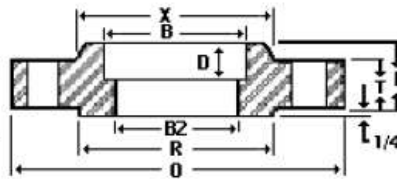

Socket Weld Flange

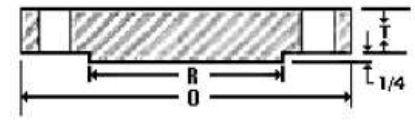

Blind Flange

Nom. Pipe Size	O	T	R	X	No. & Dia. of Holes	Bolt Circle Dia.	L2	H	B2	L	B	r	L3	D	B3	THr
1/2	4.75	0.88	1.38	1.50	4-0.88	3.25	2.38	0.84		1.25	0.88	0.13	1.25	0.38	0.90	0.88
3/4	5.13	1.00	1.69	1.75	4-0.88	3.50	2.75	1.05		1.38	1.09	0.13	1.38	0.44	1.11	1.00
1	5.88	1.13	2.00	2.06	4-1.00	4.00	2.88	1.32		1.63	1.36	0.13	1.63	0.50	1.38	1.13
1-1/4	6.25	1.13	2.50	2.50	4-1.00	4.38	2.88	1.66		1.63	1.70	0.19	1.63	0.56	1.72	1.19
1-1/2	7.00	1.25	2.88	2.75	4-1.13	4.88	3.25	1.90		1.75	1.95	0.25	1.75	0.63	1.97	1.25
2	8.50	1.50	3.63	4.13	8-1.00	6.50	4.00	2.38		2.25	2.44	0.31	2.25	0.69	2.46	1.50
2-1/2	9.63	1.63	4.13	4.88	8-1.13	7.50	4.13	2.88		2.50	2.94	0.31	2.50	0.75	2.97	1.88
3	10.50	1.88	5.00	5.25	8-1.25	8.00	4.63	3.50		2.88	3.57	0.38	2.88	--	3.60	2.00
4	12.25	2.13	6.19	6.38	8-1.38	9.50	4.88	4.50		3.56	4.57	0.44	3.56	--	4.60	2.25
5	14.75	2.88	7.31	7.75	8-1.63	11.50	6.13	5.56		4.13	5.66	0.44	4.13	--	5.69	2.50
6	15.50	3.25	8.50	9.00	12-1.50	12.50	6.75	6.63		4.69	6.72	0.50	4.69	--	6.75	2.75
8	19.00	3.63	10.63	11.50	12-1.75	15.50	8.38	8.63		5.63	8.72	0.50	5.63	--	8.75	3.00
10	23.00	4.25	12.75	14.50	12-2.00	19.00	10.00	10.75		6.25	10.88	0.50	7.00	--	10.92	3.31
12	26.50	4.88	15.00	17.75	16-2.13	22.50	11.13	12.75		7.13	12.88	0.50	8.63	--	12.92	3.63
14	29.50	5.25	16.25	19.50	16-2.38	25.00	11.75	14.00		--	--	0.50	9.50	--	14.18	--
16	32.50	5.75	18.50	21.75	16-2.63	27.75	12.25	16.00		--	--	0.50	10.25	--	16.19	--
18	36.00	6.38	21.00	23.50	16-2.88	30.50	12.88	18.00		--	--	0.50	10.88	--	18.20	--
20	38.75	7.00	23.00	25.25	16-3.13	32.75	14.00	20.00		--	--	0.50	11.50	--	20.25	--
24	46.00	8.00	27.25	30.00	16-3.63	39.00	16.00	24.00		--	--	0.50	13.00	--	24.25	--

To be specified by purchaser.

Dimensions in inches.

1. 1/4 in. raised face not included in dimensions T, L and L2.
2. Bolt hole diameter 1/8 in. larger than bolt diameter.

ANSI B16.5 Class 2500 Flanges

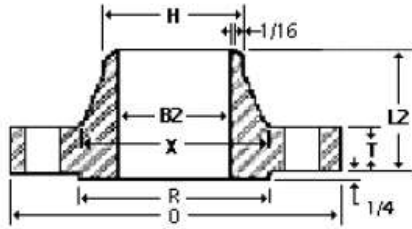

Weld Neck Flange

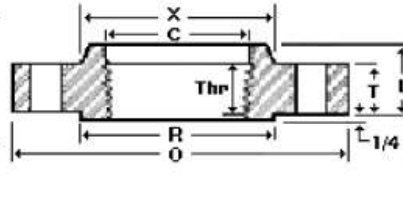

Threaded Flange

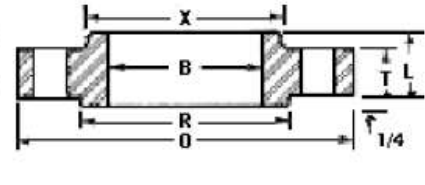

Slip On Flange

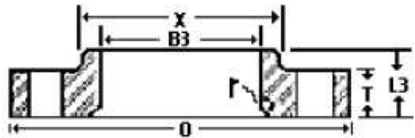

Lap Joint Flange

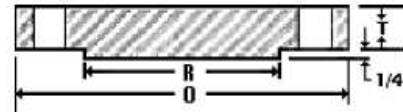

Blind Flange

Nom. Pipe Size	O	T	R	X	No. & Dia. of Holes	Bolt Circle Dia.	L2	H	B2	L	B	r	L3	B3	Thr
1/2	5.25	1.19	1.38	1.69	4-0.88	3.50	2.88	0.84	To be specified by purchaser.	1.56	0.88	0.13	1.56	0.90	1.13
3/4	5.50	1.25	1.69	2.00	4-0.88	3.75	3.13	1.05		1.69	1.09	0.13	1.69	1.11	1.25
1	6.25	1.38	2.00	2.25	4-1.00	4.25	3.50	1.32		1.88	1.36	0.13	1.88	1.38	1.38
1-1/4	7.25	1.50	2.50	2.88	4-1.13	5.13	3.75	1.66		2.06	1.70	0.18	2.06	1.72	1.50
1-1/2	8.00	1.75	2.88	3.13	4-1.25	5.75	4.38	1.90		2.38	1.95	0.25	2.38	1.97	1.75
2	9.25	2.00	3.63	3.75	8-1.13	6.75	5.00	2.38		2.75	2.44	0.31	2.75	2.46	2.00
2-1/2	10.50	2.25	4.13	4.50	8-1.25	7.75	5.63	2.88		3.13	2.94	0.31	3.13	2.97	2.25
3	12.00	2.63	5.00	5.25	8-1.38	9.00	6.63	3.50		3.63	3.57	0.37	3.63	3.60	2.50
4	14.00	3.00	6.19	6.50	8-1.63	10.75	7.50	4.50		4.25	4.57	0.44	4.25	4.60	2.75
5	16.50	3.63	7.31	8.00	8-1.88	12.75	9.00	5.56		5.13	5.66	0.44	5.13	5.69	3.00
6	19.00	4.25	8.50	9.25	8-2.13	14.50	10.75	6.63		6.00	6.72	0.50	6.00	6.75	3.25
8	21.75	5.00	10.63	12.00	12-2.13	17.25	12.50	8.63		7.00	8.72	0.50	7.00	8.75	3.75
10	26.50	6.50	12.75	14.75	12-2.63	21.25	16.50	10.75	9.00	10.88	0.50	9.00	10.92	4.25	
12	30.00	7.25	15.00	17.38	12-2.88	24.38	18.25	12.75	10.00	12.88	0.50	10.00	12.92	4.75	

Dimensions in inches.

1. 1/4 in. raised face not included in dimensions T, L and L2.
2. Bolt hole diameter 1/8 in. larger than bolt diameter.

Dimensional Tolerance - ANSI B16.5

Threaded, Socket-Welding, Slip-On, Lap Joint and Blind			
Outside Diameter *	6" and below		±1.5mm
	8" ~ 24"		±2.0mm
	over 24"		±3.0mm
Inside Diameter	Threaded		Within limits on boring gauge
	Socket-Welding, Slip-On and Lap-Joint	2-1/2" and below	+0.5mm -0mm
		3" ~ 10"	+0.8mm -0mm
		12" and above	+1.6mm -0mm
Outside Diameter of Hub *	1/2" ~ 24"		+3.0mm -1.0mm
Diameter of Contact Face	1/16" Raised Face		±0.8mm
	1/4" Raised Face Tongue & Groove Male, Female		±0.5mm
Diameter of Counter Bore	Same as for Inside Diameter		
Drilling	Bore	6" and below	±1.0mm
		8" ~ 24"	±1.6mm
	Eccentricity of Bore		±0.8mm
	Diameter of Bolt Hole		±0.5mm
	Bolt hole spacing 24" and above		±0.8mm
Thickness	1/2" ~ 4"		+1.6mm -0mm
	5" ~ 12"		+2.0mm -0mm
	14" ~ 18"		+3.0mm -0mm
	20" and above		+4.0mm -0mm
Length Through the Hub *	1/2" ~ 10"		±1.6mm
	12" and above		±3.0mm

Weld Neck			
Outside Diameter *	6" and below		±1.5mm
	8" ~ 24"		±2.0mm
	over 24"		±3.0mm
Inside Diameter	1/2" ~ 10"		+0.8mm -0mm
	12" ~ 18"		±1.6mm
	20" and above		+3.2mm -1.6mm
Diameter of Hub at Base *	1/2" ~ 24"		+3.0mm -1.0mm
Diameter of Contact Face	1/16" Raised Face		±0.8mm
	1/4" Raised Face Tongue & Groove Male, Female		±0.5mm
Diameter of Hub at Point of Welding	1/2" ~ 5"		+2.4mm -0.8mm
	6" and above		+4.0mm -0.8mm
Drilling	Bore	6" and below	±1.0mm
		8" ~ 24"	±1.6mm
	Eccentricity of Bore		±0.8mm
	Diameter of Bolt Hole		±0.5mm
	Bolt hole spacing 24" and above		±0.8mm
Thickness	1/2" ~ 4"		+1.6mm -0mm
	5" ~ 12"		+2.0mm -0mm
	14" ~ 18"		+3.0mm -0mm
	20" and above		+4.0mm -0mm
Length Through the Hub	1/2" ~ 10"		±1.6mm
	12" and above		±3.0mm

* Tolerances not listed in B16.5

Welding Bevel Standards

For Wall Thickness "t" 3/16" to 3/4" including

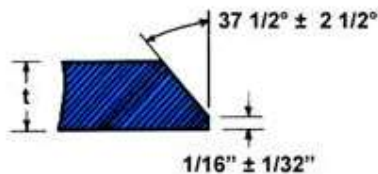

For Wall Thickness "t" greater than 3/4"

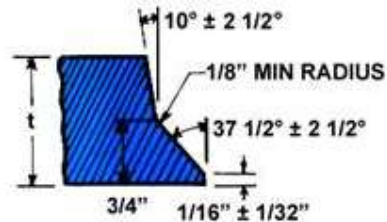

ANSI B16.47 Series A Class 150 Flanges

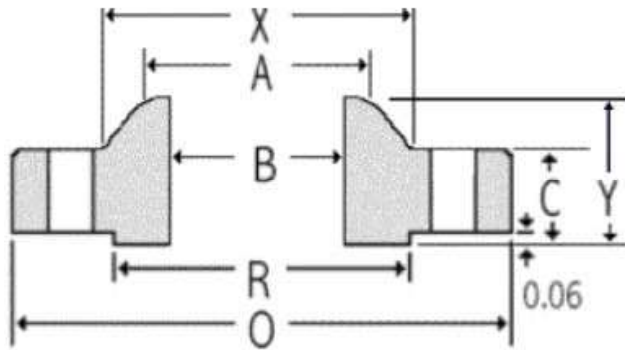

Weld Neck

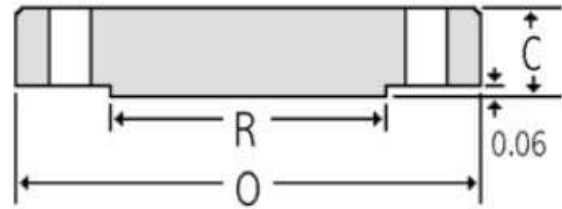

Blind

Nom. Pipe Size	Thickness					Bore	LTH	Dia Bevel	Drilling			Weight	
	OD	Weld Neck	Blind	OD RF	Dia at Base				Bolt Circle	Dia Holes	# Holes	Weld Neck	Blind
	O	C	C	R	X				B	Y	A		
26	34.25	2.69	2.69	29.50	26.62	To be specified by purchaser.	4.75	26.00	31.75	1.38	24.00	300	702
28	36.50	2.81	2.81	31.50	28.62		4.94	28.00	34.00	1.38	28.00	345	833
30	38.75	2.94	2.94	33.75	30.75		5.38	30.00	36.00	1.38	28.00	400	982
32	41.75	3.19	3.19	36.00	32.75		5.69	32.00	38.50	1.62	28.00	505	1237
34	43.75	3.25	3.25	38.00	34.75		5.88	34.00	40.50	1.62	32.00	540	1384
36	46.00	3.56	3.56	40.25	36.75		6.19	36.00	42.75	1.62	32.00	640	1676
38	48.75	3.44	3.44	42.25	39.00		6.19	38.00	45.25	1.62	32.00	720	1819
40	50.75	3.56	3.56	44.25	41.00		6.44	40.00	47.25	1.62	36.00	775	2040
42	53.00	3.81	3.81	47.00	43.00		6.75	42.00	49.50	1.62	36.00	890	2381
44	55.25	4.00	4.00	49.00	45.00		7.00	44.00	51.75	1.62	40.00	990	2717
46	57.25	4.06	4.06	51.00	47.12		7.31	46.00	53.75	1.62	40.00	1060	2961
48	59.50	4.25	4.25	53.50	49.12		7.56	48.00	56.00	1.62	44.00	1185	3348
50	61.75	4.38	4.38	55.50	51.25		8.00	50.00	58.25	1.88	44.00	1270	3716
52	64.00	4.56	4.56	57.50	53.25		8.25	52.00	60.50	1.88	44.00	1410	4156
54	66.25	4.75	4.75	59.50	55.25		8.50	54.00	62.75	1.88	44.00	1585	4639
56	68.75	4.88	4.88	62.00	57.38		9.00	56.00	65.00	1.88	48.00	1760	5132
58	71.00	5.06	5.06	64.00	59.38		9.25	58.00	67.25	1.88	48.00	1915	5675
60	73.00	5.19	5.19	66.00	61.38		9.44	60.00	69.25	1.88	52.00	2045	6154

Dimensions in inches. Weight in pounds.

ANSI B16.47 Series A Class 300 Flanges

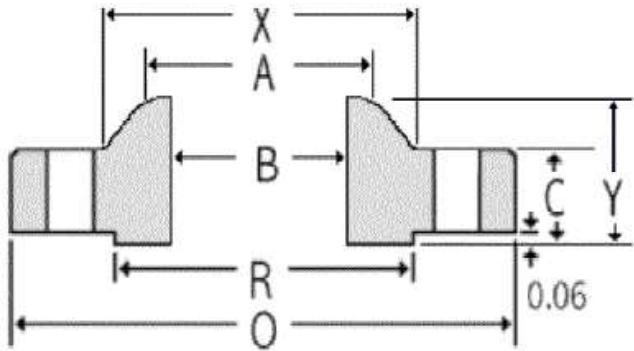

Weld Neck Flange

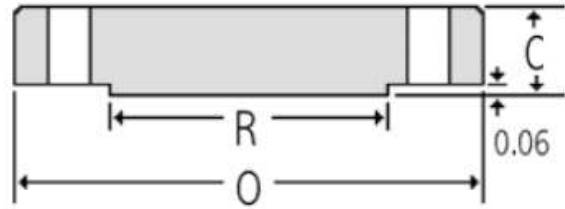

Blind Flange

Nom. Pipe Size	Thickness					Bore	Drilling					Weight	
	OD	Weld Neck	Blind	OD RF	Dia at Base		LTH	Dia Bevel	Bolt Circle	Dia Holes	# Holes	Weld Neck	Blind
	O	C	C	R	X		Y	A					
26	38.25	3.12	3.31	29.50	28.38	To be specified by purchaser.	7.25	26.00	34.50	1.75	28.00	605	1078
28	40.75	3.38	3.56	31.50	30.50		7.75	28.00	37.00	1.75	28.00	745	1315
30	43.00	3.62	3.75	33.75	32.56		8.25	30.00	39.25	1.88	28.00	870	1543
32	45.25	3.88	3.94	36.00	34.69		8.75	32.00	41.50	2.00	28.00	1005	1795
34	47.50	4.00	4.12	38.00	36.88		9.12	34.00	43.50	2.00	28.00	1145	2068
36	50.00	4.12	4.38	40.25	39.00		9.50	36.00	46.00	2.12	32.00	1275	2436
38	46.00	4.25	4.25	40.50	39.12		7.12	38.00	43.00	1.62	32.00	695	2001
40	48.75	4.50	4.50	42.75	41.25		7.62	40.00	45.50	1.75	32.00	840	2380
42	50.75	4.69	4.69	44.75	43.25		7.88	42.00	47.50	1.75	32.00	950	2688
44	53.25	4.88	4.88	47.00	45.25		8.12	44.00	49.75	1.88	32.00	1055	3079
46	55.75	5.06	5.06	49.00	47.38		8.50	46.00	52.00	2.00	28.00	1235	3499
48	57.75	5.25	5.25	51.25	49.38		8.81	48.00	54.00	2.00	32.00	1380	3896
50	60.25	5.50	5.50	53.50	51.38		9.12	50.00	56.25	2.12	32.00	1530	4442
52	62.25	5.69	5.69	55.50	53.38		9.38	52.00	58.25	2.12	32.00	1660	4906
54	65.25	6.00	6.00	57.75	55.50		9.94	54.00	61.00	2.38	28.00	2050	5684
56	67.25	6.06	6.06	59.75	57.62		10.25	56.00	63.00	2.38	28.00	2155	6098
58	69.25	6.25	6.25	62.00	59.62		10.50	58.00	65.00	2.38	32.00	2270	6669
60	71.25	6.44	6.44	64.00	61.62		10.75	60.00	67.00	2.38	32.00	2470	7274

Dimensions in inches. Weights in pounds.

Note: Larger sizes as well as intermediate sizes can be furnished.

ANSI B16.47 Series A Class 400 Flanges

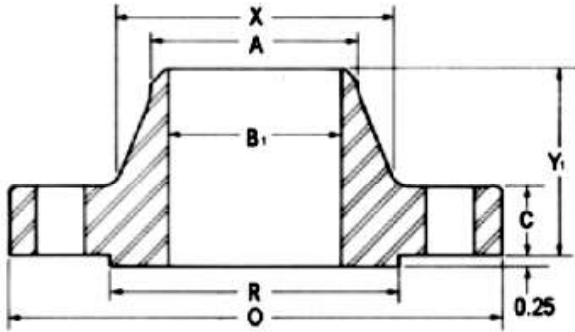

Weld Neck Flange

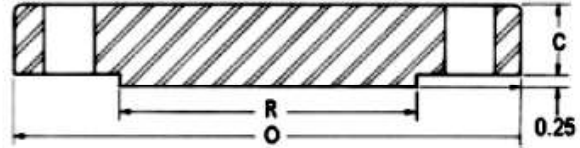

Blind Flange

Nom. Pipe Size	Thickness							Drilling			Weight	
	OD	Weld Neck	Blind	LTH	Dia at Base	Dia Bevel	OD RF	Bolt Circle	# Holes	Dia Holes	Weld Neck	Blind
	O	C	C	Y	X	A	R					
26	38.25	3.50	3.88	7.62	28.62	26.00	29.50	34.50	28.00	1.88	650	1263
28	40.75	3.75	4.12	8.12	30.81	28.00	31.50	37.00	28.00	2.00	785	1522
30	43.00	4.00	4.38	8.62	32.94	30.00	33.75	39.25	28.00	2.12	905	1802
32	45.25	4.25	4.56	9.12	35.00	32.00	36.00	41.50	28.00	2.12	1065	2077
34	47.50	4.38	4.81	9.50	37.19	34.00	38.00	43.50	28.00	2.12	1200	2415
36	50.00	4.50	5.06	9.88	39.38	36.00	40.25	46.00	32.00	2.12	1340	2815
38	47.50	4.88	4.88	8.12	39.50	38.00	40.75	44.00	32.00	1.88	935	2450
40	50.00	5.12	5.12	8.50	41.50	40.00	43.00	46.25	32.00	2.00	1090	2848
42	52.00	5.25	5.25	8.81	43.62	42.00	45.00	48.25	32.00	2.00	1190	3159
44	54.50	5.50	5.50	9.18	45.62	44.00	47.25	50.50	32.00	2.12	1375	3635
46	56.75	5.75	5.75	9.62	47.75	46.00	49.50	52.75	36.00	2.12	1525	4120
48	59.50	6.00	6.00	10.12	49.88	48.00	51.50	55.25	28.00	2.38	1790	4726
50	61.75	6.19	6.25	10.56	52.00	50.00	53.62	57.50	32.00	2.38	1950	5303
52	63.75	6.38	6.44	10.88	54.00	52.00	55.62	59.50	32.00	2.38	2125	5823
54	67.00	6.69	6.75	11.38	56.12	54.00	57.88	62.25	28.00	2.62	2565	6742
56	69.00	6.88	6.94	11.75	58.25	56.00	60.12	64.25	32.00	2.62	2710	7352
58	71.00	7.00	7.12	12.06	60.25	58.00	62.12	66.25	32.00	2.62	3230	7986
60	74.25	7.31	7.44	12.56	62.38	60.00	64.38	69.00	32.00	2.88	3820	9126

Dimensions in inches. Weights in pounds.

Note: Larger sizes as well as intermediate sizes can be furnished.

ANSI B16.47 Series A Class 600 Flanges

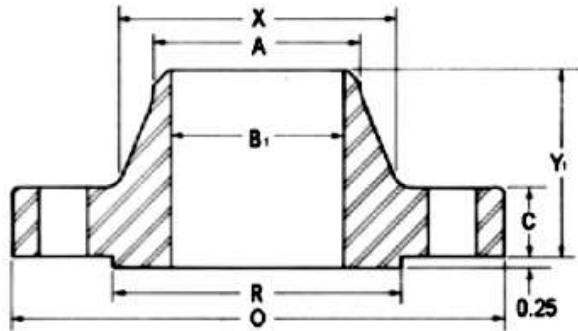

Weld Neck Flange

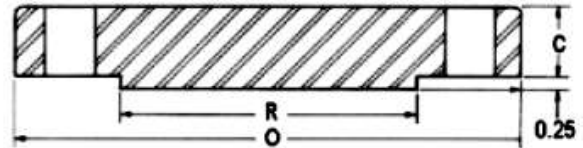

Blind Flange

Nom. Pipe Size	Thickness							Drilling			Weight	
	OD	Weld Neck	Blind	LTH	Dia at Base	Dia Bevel	OD RF	Bolt Circle	# Holes	Dia Holes	Weld Neck	Blind
	O	C	C	Y	X	A	R					
26	40.00	4.25	4.94	8.75	29.44	26.00	29.50	36.00	28.00	2.00	940	1759
28	42.25	4.38	5.19	9.25	31.62	28.00	31.50	38.00	28.00	2.12	1060	2061
30	44.50	4.50	5.50	9.75	33.94	30.00	33.75	40.25	28.00	2.12	1210	2423
32	47.00	4.62	5.81	10.25	36.12	32.00	36.00	42.50	28.00	2.38	1375	2856
34	49.00	4.75	6.06	10.62	38.31	34.00	38.00	44.50	28.00	2.38	1540	3237
36	51.75	4.88	6.38	11.12	40.62	36.00	40.25	47.00	28.00	2.62	1705	3802
38	50.00	6.00	6.12	10.00	40.25	38.00	41.50	45.75	28.00	2.38	1470	3404
40	52.00	6.25	6.38	10.38	42.25	40.00	43.75	47.75	32.00	2.38	1630	3838
42	55.25	6.62	6.75	11.00	44.38	42.00	46.00	50.50	28.00	2.62	2030	4585
44	57.25	6.81	7.00	11.38	46.50	44.00	48.25	52.50	32.00	2.62	2160	5105
46	59.50	7.06	7.31	11.81	48.62	46.00	50.25	54.75	32.00	2.62	2410	5758
48	62.75	7.44	7.69	12.44	50.75	48.00	52.50	57.50	32.00	2.88	2855	6737
50	65.75	7.75	8.00	12.94	52.88	50.00	54.50	60.00	28.00	3.12	3330	7695
52	67.75	8.00	8.25	13.25	54.88	52.00	56.50	62.00	32.00	3.12	3560	8426
54	70.00	8.25	8.56	13.75	57.00	54.00	58.75	64.25	32.00	3.12	3920	9333
56	73.00	8.56	8.88	14.25	59.12	56.00	60.75	66.75	32.00	3.38	4280	10529
58	75.00	8.75	9.12	14.56	61.12	58.00	63.00	68.75	32.00	3.38	4640	11414
60	78.50	9.19	9.56	15.31	63.38	60.00	65.25	71.75	28.00	3.62	5000	13108

Dimensions in inches. Weights in pounds.

Note: Larger sizes as well as intermediate sizes can be furnished.

ANSI B16.47 Series A Class 900 Flanges

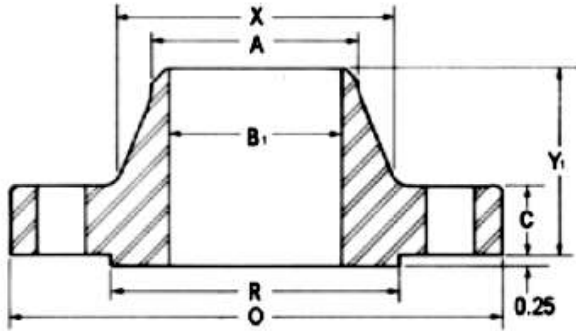

Weld Neck Flange

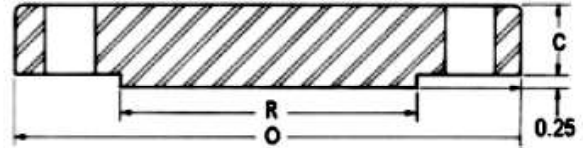

Blind Flange

Nom. Pipe Size	Thickness							Drilling			Weight	
	OD	Weld Neck	Blind	LTH	Dia at Base	Dia Bevel	OD RF	Bolt Circle	# Holes	Dia Holes	Weld Neck	Blind
	O	C	C	Y	X	A	R					
26	42.75	5.50	6.31	11.25	30.50	26.00	29.50	37.50	20.00	2.88	1,525	2,566
28	46.00	5.62	6.75	11.75	32.75	28.00	31.50	40.25	20.00	3.12	1,810	3,178
30	48.50	5.88	7.18	12.25	35.00	30.00	33.75	42.75	20.00	3.12	2,120	3,758
32	51.75	6.25	7.62	13.00	37.25	32.00	36.00	45.50	20.00	3.38	2,545	4,541
34	55.00	6.50	8.06	13.75	39.62	34.00	38.00	48.25	20.00	3.62	2,970	5,425
36	57.50	6.75	8.44	14.25	41.88	36.00	40.25	50.75	20.00	3.62	3,395	6,209
38	57.50	7.50	8.50	13.88	42.25	38.00	43.25	50.75	20.00	3.62	3,385	6,253
40	59.50	7.75	8.81	14.31	44.38	40.00	45.75	52.75	24.00	3.62	3,620	6,940
42	61.50	8.12	9.12	14.62	46.31	42.00	47.75	54.75	24.00	3.62	3,960	7,675
44	64.88	8.44	9.56	15.38	48.62	44.00	50.00	57.62	24.00	3.88	4,300	8,954
46	68.25	8.88	10.06	16.18	50.88	46.00	52.50	60.50	24.00	4.12	4,640	10,426
48	70.25	9.19	10.38	16.50	52.88	48.00	54.50	62.50	24.00	4.12	4,980	11,398

Dimensions in inches. Weights in pounds.

Note: Larger sizes as well as intermediate sizes can be furnished.

ANSI B16.47 Series B Class 75 Flanges

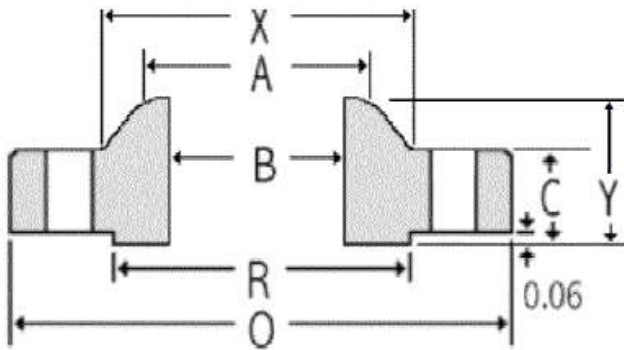

Weld Neck

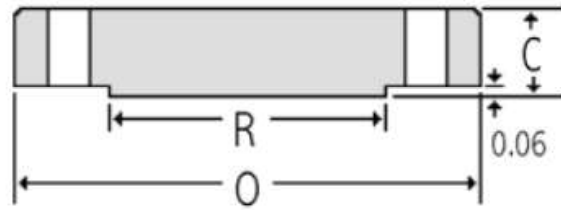

Blind

Nom. Pipe Size	Thickness					Bore	LTH	Dia Bevel	Drilling			Weight	
	OD	Weld Neck	Blind	OD RF	Dia at Base				Bolt Circle	Dia Holes	# Holes	Weld Neck	Blind
	O	C	C	R	X				B	Y	A		
26	30.00	1.31	1.31	27.75	26.62	To be specified by purchaser.	2.31	26.06	28.50	0.75	36.00	80	255
28	32.00	1.31	1.31	29.75	28.62		2.44	28.06	30.50	0.75	40.00	85	290
30	34.00	1.31	1.31	31.75	30.62		2.56	30.06	32.50	0.75	44.00	90	330
32	36.00	1.38	1.44	33.75	32.62		2.75	32.06	34.50	0.75	48.00	105	390
34	38.00	1.38	1.50	35.75	34.62		2.88	34.06	36.50	0.75	52.00	110	430
36	40.69	1.44	1.67	38.00	36.81		3.38	36.06	39.06	0.88	40.00	145	518
38	42.69	1.50	1.75	40.00	38.81		3.50	38.06	41.06	0.88	40.00	160	595
40	44.69	1.50	1.75	42.00	40.81		3.62	40.06	43.06	0.88	44.00	170	760
42	46.69	1.56	1.88	44.00	42.81		3.75	42.06	45.06	0.88	48.00	185	895
44	49.25	1.69	1.94	46.25	44.88		4.12	44.06	47.38	1.00	36.00	230	1,065
46	51.25	1.75	2.00	48.25	46.88		4.25	46.06	49.38	1.00	40.00	245	1,185
48	53.25	1.81	2.12	50.25	48.88		4.38	48.06	51.38	1.00	44.00	270	1,315
50	55.25	1.88	2.18	52.25	50.94		4.56	50.06	53.38	1.00	44.00	290	1,505
52	57.38	1.88	2.25	54.25	52.94		4.75	52.06	55.50	1.00	48.00	310	1,665
54	59.38	1.94	2.38	56.25	55.00		4.94	54.06	57.50	1.00	48.00	340	1,840
56	62.00	2.00	2.44	58.50	57.12		5.31	56.06	59.88	1.12	40.00	400	2,110
58	64.00	2.06	2.50	60.50	59.12		5.44	58.06	61.88	1.12	44.00	430	2,300
60	66.00	2.19	2.62	62.50	61.12		5.69	60.06	63.88	1.12	44.00	475	2,500

Dimensions in inches.

Note: Larger sizes as well as intermediate sizes can be furnished.

ANSI B16.47 Series B Class 150 Flanges

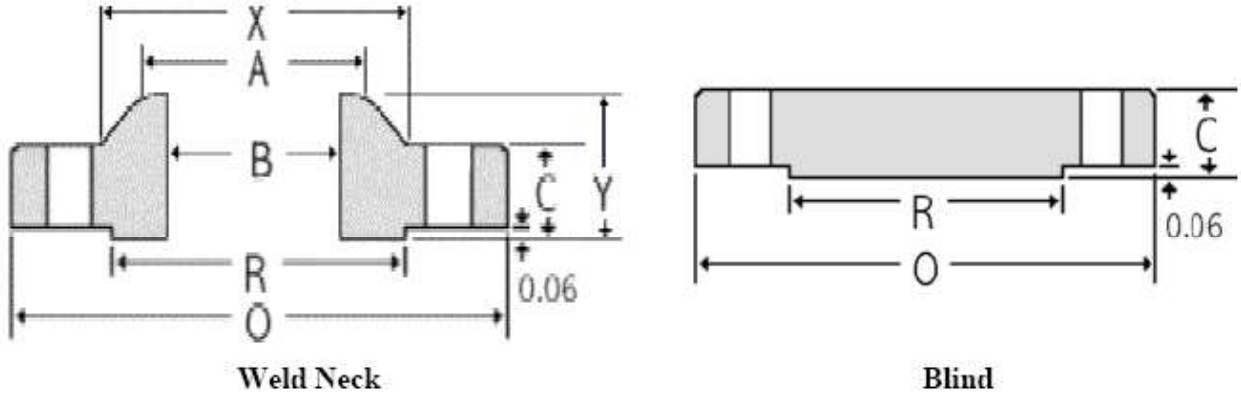

Dimensions in inches.

Note: Larger sizes as well as intermediate sizes can be furnished.

Nom. Pipe Size	Thickness					Bore	LTH	Dia Bevel	Drilling			Weight	
	OD	Weld Neck	Blind	OD RF	Dia at Base				Bolt Circle	Dia Holes	# Holes	Weld Neck	Blind
	O	C	C	R	X				B	Y	A		
26	30.94	1.62	1.75	28.00	26.94	To be specified by purchaser.	3.50	26.06	29.31	0.88	36.00	120	373
28	32.94	1.75	1.88	30.00	28.94		3.75	28.06	31.31	0.88	40.00	140	454
30	34.94	1.75	2.00	32.00	31.00		3.94	30.06	33.31	0.88	44.00	150	543
32	37.06	1.81	2.12	34.00	33.06		4.25	32.06	35.44	0.88	48.00	170	648
34	39.56	1.94	2.25	36.25	35.12		4.34	34.06	37.69	1.00	40.00	210	783
36	41.62	2.06	2.31	38.25	37.19		4.62	36.06	39.75	1.00	44.00	240	890
38	44.25	2.12	2.50	40.25	39.25		4.88	38.12	42.12	1.12	40.00	290	1,089
40	46.25	2.19	2.62	42.50	41.31		5.06	40.12	44.12	1.12	44.00	310	1,247
42	48.25	2.31	2.69	44.50	43.38		5.25	42.12	46.12	1.12	48.00	345	1,393
44	50.25	2.38	2.81	46.50	45.38		5.38	44.12	48.12	1.12	52.00	370	1,579
46	52.81	2.44	2.94	48.62	47.44		5.69	46.12	50.56	1.25	40.00	435	1,824
48	54.81	2.56	3.06	50.75	49.50		5.88	48.12	52.56	1.25	44.00	480	2,045
50	56.81	2.69	3.18	52.75	51.50		6.06	50.12	54.56	1.25	48.00	520	2,284
52	58.81	2.75	3.31	54.75	53.56		6.19	52.12	56.56	1.25	52.00	550	2,547
54	61.00	2.81	3.44	56.75	55.62		6.38	54.12	58.75	1.25	56.00	620	2,848
56	63.00	2.88	3.56	58.75	57.69		6.56	56.12	60.75	1.25	60.00	650	3,144
58	65.94	2.94	3.68	60.75	59.69	6.88	58.12	63.44	1.38	48.00	780	3,560	
60	67.94	3.00	3.81	63.00	61.81	7.06	60.12	65.44	1.38	52.00	850	3,913	

ANSI B16.47 Series B Class 300 Flanges

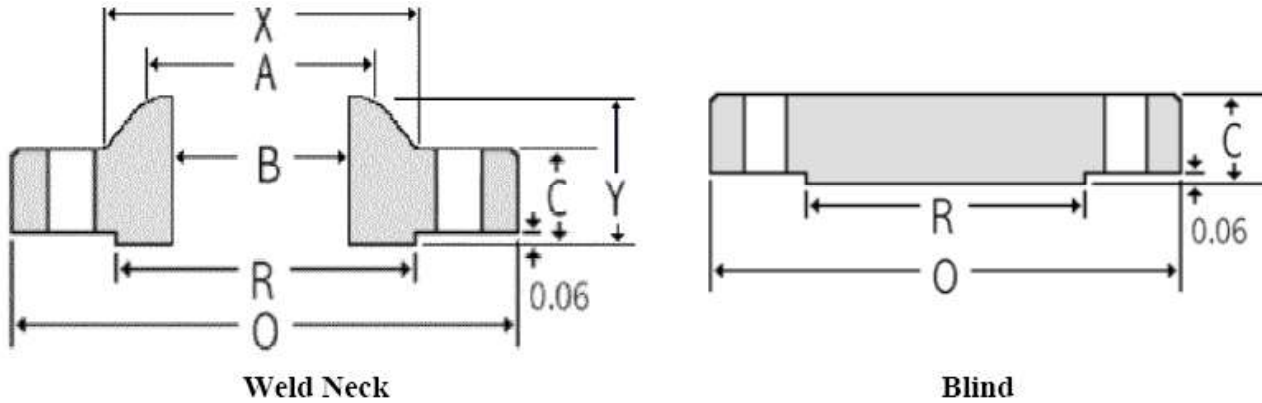

Nom. Pipe Size	Thickness					Bore	LTH	Dia Bevel	Drilling			Weight	
	OD	Weld Neck	Blind	OD RF	Dia at Base				Bolt Circle	Dia Holes	# Holes	Weld Neck	Blind
	O	C	C	R	X				B	Y	A		
26	34.12	3.50	3.50	29.00	27.62	To be specified by purchaser.	5.69	26.19	31.62	1.38	32.00	400	907
28	36.25	3.50	3.50	31.00	29.75		5.88	28.19	33.75	1.38	36.00	450	1,023
30	39.00	3.69	3.69	33.25	32.00		6.22	30.25	36.25	1.50	36.00	550	1,249
32	41.50	4.06	4.06	35.50	34.00		6.62	32.25	38.50	1.62	32.00	685	1,556
34	43.62	4.06	4.06	37.50	36.12		6.81	34.25	40.62	1.62	36.00	750	1,719
36	46.12	4.06	4.06	39.75	38.00		7.12	36.25	42.88	1.75	32.00	840	1,921
38	48.12	4.38	4.38	41.75	40.00		7.56	38.25	44.88	1.75	36.00	915	2,257
40	50.12	4.56	4.56	43.88	42.00		7.81	40.25	46.88	1.75	40.00	990	2,549
42	52.50	4.69	4.69	46.00	44.00		8.06	42.31	49.00	1.88	36.00	1,135	2,876
44	54.50	5.00	5.00	48.00	46.19		8.44	44.31	51.00	1.88	40.00	1,235	3,304
46	57.50	5.06	5.12	50.00	48.38		8.75	46.31	53.75	2.00	36.00	1,470	3,766
48	59.50	5.06	5.31	52.25	50.31		8.81	48.31	55.75	2.00	40.00	1,575	4,183
50	61.50	5.44	5.50	54.25	52.38		9.25	50.31	57.75	2.00	44.00	1,710	4,629
52	63.50	5.62	5.68	56.25	54.44		9.56	52.31	59.75	2.00	48.00	1,840	5,096
54	65.88	5.38	5.88	58.25	56.50		9.44	54.31	62.12	2.00	48.00	1,980	5,678
56	69.50	6.06	6.18	60.50	58.81		10.56	56.31	65.00	2.38	36.00	2,595	6,642
58	71.94	6.06	6.38	62.75	60.94		10.81	58.31	67.44	2.38	40.00	2,770	7,347
60	73.94	5.94	6.56	65.00	62.94		10.69	60.31	69.44	2.38	40.00	2,870	7,980

Dimensions in inches.

Note: Larger sizes as well as intermediate sizes can be furnished.

ANSI B16.47 Series B Class 400 Flanges

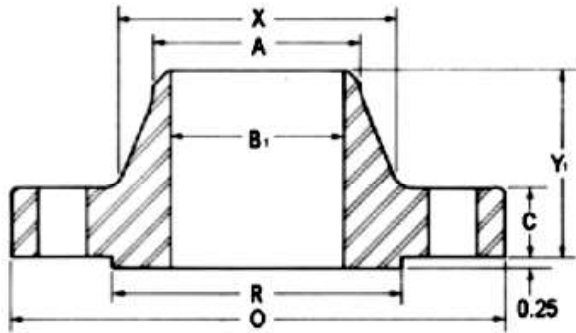

Weld Neck

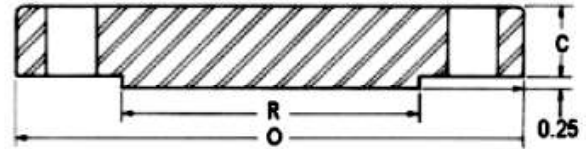

Blind

Nom. Pipe Size	Thickness							Drilling			Weight	
	OD	Weld Neck	Blind	LTH	Dia at Base	Dia Bevel	OD RF	Bolt Circle	# Holes	Dia Holes	Weld Neck	Blind
	O	C	C	Y	X	A	R					
26	33.50	3.50	3.50	5.88	27.12	26.00	28.00	30.75	28.00	1.50	360	874
28	36.00	3.75	3.75	6.25	29.12	28.00	30.00	33.00	24.00	1.62	450	1,081
30	38.25	4.00	4.00	6.69	31.25	30.00	32.25	35.25	28.00	1.62	530	1,302
32	40.75	4.25	4.25	7.06	33.25	32.00	34.38	37.50	28.00	1.75	635	1,570
34	42.75	4.38	4.38	7.38	35.38	34.00	36.50	39.50	32.00	1.75	690	1,781
36	45.50	4.69	4.69	7.88	37.50	36.00	38.62	42.00	28.00	1.88	855	2,160
38	47.50	4.88	4.88	8.12	39.50	38.00	40.75	44.00	32.00	1.88	935	2,450
40	50.00	5.12	5.12	8.50	41.50	40.00	43.00	46.25	32.00	2.00	1,090	2,848
42	52.00	5.25	5.25	8.81	43.62	42.00	45.00	48.25	32.00	2.00	1,190	3,159
44	54.50	5.50	5.50	9.18	45.62	44.00	47.25	50.50	32.00	2.12	1,375	3,635
46	56.75	5.75	5.75	9.62	47.75	46.00	49.50	52.75	36.00	2.12	1,525	4,120
48	59.50	6.00	6.00	10.12	49.88	48.00	51.50	55.25	28.00	2.38	1,790	4,726
50	61.75	6.19	6.25	10.56	52.00	50.00	53.62	57.50	32.00	2.38	1,950	5,303
52	63.75	6.38	6.44	10.88	54.00	52.00	55.62	59.50	32.00	2.38	2,125	5,823
54	67.00	6.69	6.75	11.38	56.12	54.00	57.88	62.25	28.00	2.62	2,565	6,742
56	69.00	6.88	6.94	11.75	58.25	56.00	60.12	64.25	32.00	2.62	2,710	7,352
58	71.00	7.00	7.12	12.06	60.25	58.00	62.12	66.25	32.00	2.62	3,230	7,986
60	74.25	7.31	7.44	12.56	62.38	60.00	64.38	69.00	32.00	2.88	3,820	9,126

Dimensions in inches.

Note: Larger sizes as well as intermediate sizes can be furnished.

ANSI B16.47 Series B Class 600 Flanges

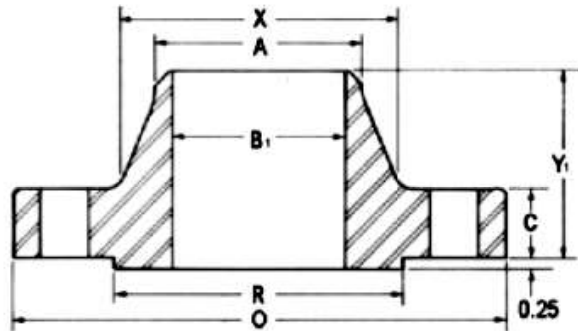

Weld Neck

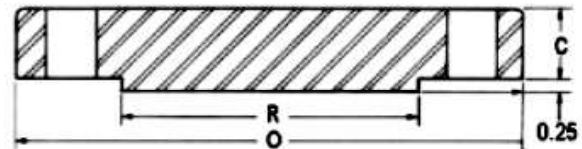

Blind

Nom. Pipe Size	Thickness							Drilling			Weight	
	OD	Weld Neck	Blind	LTH	Dia at Base	Dia Bevel	OD RF	Bolt Circle	# Holes	Dia Holes	Weld Neck	Blind
	O	C	C	Y	X	A	R					
26	35.00	4.38	4.38	7.12	27.50	26.00	28.62	31.75	28.00	1.75	550	1,194
28	37.50	4.56	4.56	7.50	29.62	28.00	30.88	34.00	28.00	1.88	650	1,427
30	40.25	4.94	5.00	8.06	31.75	30.00	33.12	36.50	28.00	2.00	810	1,802
32	42.75	5.12	5.31	8.50	33.88	32.00	35.25	38.75	28.00	2.12	950	2,159
34	45.75	5.56	5.68	9.19	36.00	34.00	37.50	41.50	24.00	2.38	1,205	2,645
36	47.75	5.75	5.94	9.56	38.12	36.00	39.75	43.50	28.00	2.38	1,340	3,013
38	50.00	6.00	6.12	10.00	40.25	38.00	41.50	45.75	28.00	2.38	1,470	3,404
40	52.00	6.25	6.38	10.38	42.25	40.00	43.75	47.75	32.00	2.38	1,630	3,838
42	55.25	6.62	6.75	11.00	44.38	42.00	46.00	50.50	28.00	2.62	2,030	4,585
44	57.25	6.81	7.00	11.38	46.50	44.00	48.25	52.50	32.00	2.62	2,160	5,105
46	59.50	7.06	7.31	11.81	48.62	46.00	50.25	54.75	32.00	2.62	2,410	5,758
48	62.75	7.44	7.69	12.44	50.75	48.00	52.50	57.50	32.00	2.88	2,855	6,737
50	65.75	7.75	8.00	12.94	52.88	50.00	54.50	60.00	28.00	3.12	3,330	7,695
52	67.75	8.00	8.25	13.25	54.88	52.00	56.50	62.00	32.00	3.12	3,560	8,426
54	70.00	8.25	8.56	13.75	57.00	54.00	58.75	64.25	32.00	3.12	3,920	9,333
56	73.00	8.56	8.88	14.25	59.12	56.00	60.75	66.75	32.00	3.38	4,280	10,529
58	75.00	8.75	9.12	14.56	61.12	58.00	63.00	68.75	32.00	3.38	4,640	11,414
60	78.50	9.19	9.56	15.31	63.38	60.00	65.25	71.75	28.00	3.62	5,000	13,108

Dimensions in inches.

Note: Larger sizes as well as intermediate sizes can be furnished.

ANSI B16.47 Series B Class 900 Flanges

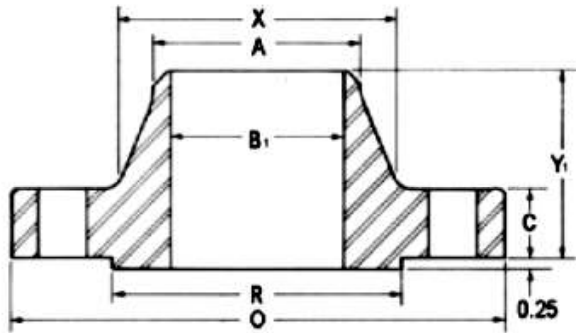

Weld Neck

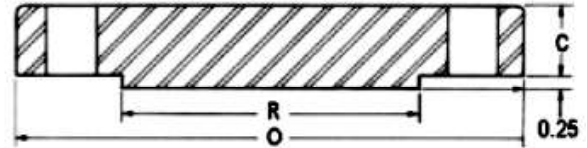

Blind

Nom. Pipe Size	Thickness							Drilling			Weight	
	OD	Weld Neck	Blind	LTH	Dia at Base	Dia Bevel	OD RF	Bolt Circle	# Holes	Dia Holes	Weld Neck	Blind
	O	C	C	Y	X	A	R					
26	40.25	5.31	6.06	10.19	29.25	26.00	30.00	35.50	20.00	2.62	1,050	2,184
28	43.50	5.81	6.56	10.88	31.38	28.00	32.25	38.25	20.00	2.88	1,520	2,762
30	46.50	6.12	6.93	11.38	33.50	30.00	34.50	40.75	20.00	3.12	1,820	3,334
32	48.75	6.31	7.31	11.94	35.75	32.00	36.50	43.00	20.00	3.12	2,065	3,865
34	51.75	6.75	7.68	12.56	37.88	34.00	39.00	45.50	20.00	3.38	2,450	4,576
36	53.00	6.81	7.94	12.81	40.00	36.00	40.50	47.25	24.00	3.12	2,520	4,963
38	57.50	7.50	8.50	13.88	42.25	38.00	43.25	50.75	20.00	3.62	3,385	6,253
40	59.50	7.75	8.81	14.31	44.38	40.00	45.75	52.75	24.00	3.62	3,620	6,940
42	61.50	8.12	9.12	14.62	46.31	42.00	47.75	54.75	24.00	3.62	3,960	7,675
44	64.88	8.44	9.56	15.38	48.62	44.00	50.00	57.62	24.00	3.88	4,300	8,954
46	68.25	8.88	10.06	16.18	50.88	46.00	52.50	60.50	24.00	4.12	4,640	10,426
48	70.25	9.19	10.38	16.50	52.88	48.00	54.50	62.50	24.00	4.12	4,980	11,398

Dimensions in inches.

Note: Larger sizes as well as intermediate sizes can be furnished.