



# United Capital Group Energy L.L.C.

Quality with integrity



[www.ucgenenergy.us](http://www.ucgenenergy.us)

2023





# About the Company



A world-class Integrated **Manufacturer** in America, United Capital Group Energy L.L.C. Inc. (UCG) strives to create the best pipes, **pipe fittings, Transformers, Chemicals, Automation Systems, Oil and Gas Well head equipment, Pumps, Ware House Rack and Shelves manufacturer** in the market and works tirelessly to improve product quality, efficiency, and customer satisfaction. Our customers include large gas transmission companies, midstream companies, structural contractors, electricity generators/distributors and pipe distributors.

**OIL & GAS WELL-HEAD EQUIPMENTS | TRANSFORMERS  
AUTOMATION | PIPE FITTINGS | PUMPS | WAREHOUSE**



# Certification

**Certificate of Registration** 

This is to certify that Quality Management System of

**United Capital Group Energy L.L.C**  
2219 E. ELGIN ST. CHANDLER, AZ 85225 - UNITED STATES OF AMERICA

is in accordance with the requirements of the following standard

**ISO 9001:2015**  
(Quality Management System)

**SCOPE**

1. Trading of Oil Products & Crude Oil
2. General Trading
3. Onshore & Offshore Oil & Gas Fields and Facilities Services
4. Logistics & L&M Support
5. Supply of Industrial Equipment to Oil, Gas, Water and Electrical
6. Oil & Gas Storage Tank - EPC
7. Pipe Line Projects EPC
8. Trading of Marine Equipment Oil Vessel, Offshore Platforms & Jack Up Barges
9. Degrassing Stations - EPC
10. Steel Structure Fabrication
11. Supply Security Equipment, Security Services
12. Air Services
13. Commercial Agency

Certificate Number : 22112/0101 Initial Registration Date : 22-Nov-2022  
1<sup>st</sup> Surveillance Date : 22-Oct-2023  
2<sup>nd</sup> Surveillance Date : 22-Oct-2024  
Certificate Expiry Date : 21-Nov-2025

To verify certificate, visit at:  
[www.arscert.com](https://www.arscert.com)  
<https://uafa.com/certification.org>  
<https://www.lafcertsearch.org/>

Issued by ARS Assessment Private Limited  
Managing Director 



UAF Address : 100, North Capitol Dr., STE 202, Norfolk, VA 23502, United States of America.  
This certificate is issued by ARS Assessment Private Limited on behalf of the authority. Validity of the certificate is subject to successful completion of surveillance audits. Renewal of the certificate is subject to the conditions of the registration agreement.

**Certificate of Registration** 

This is to certify that Occupational Health and Safety Management System of

**United Capital Group Energy L.L.C**  
2219 E. ELGIN ST. CHANDLER, AZ 85225 - UNITED STATES OF AMERICA

is in accordance with the requirements of the following standard

**ISO 45001:2018**  
(Occupational Health and Safety Management System)

**SCOPE**

1. Trading of Oil Products & Crude Oil
2. General Trading
3. Onshore & Offshore Oil & Gas Fields and Facilities Services
4. Logistics & L&M Support
5. Supply of Industrial Equipment to Oil, Gas, Water and Electrical
6. Oil & Gas Storage Tank - EPC
7. Pipe Line Projects EPC
8. Trading of Marine Equipment Oil Vessel, Offshore Platforms & Jack Up Barges
9. Degrassing Stations - EPC
10. Steel Structure Fabrication
11. Supply Security Equipment, Security Services
12. Air Services
13. Commercial Agency

Certificate Number : 22112/0102 Initial Registration Date : 22-Nov-2022  
1<sup>st</sup> Surveillance Date : 22-Oct-2023  
2<sup>nd</sup> Surveillance Date : 22-Oct-2024  
Certificate Expiry Date : 21-Nov-2025

To verify certificate, visit at:  
[www.arscert.com](https://www.arscert.com)  
<https://uafa.com/certification.org>  
<https://www.lafcertsearch.org/>

Issued by ARS Assessment Private Limited  
Managing Director 



UAF Address : 100, North Capitol Dr., STE 202, Norfolk, VA 23502, United States of America.  
This certificate is issued by ARS Assessment Private Limited on behalf of the authority. Validity of the certificate is subject to successful completion of surveillance audits. Renewal of the certificate is subject to the conditions of the registration agreement.

**Certificate of Registration** 

This is to certify that Environmental Management System of

**United Capital Group Energy L.L.C**  
2219 E. ELGIN ST. CHANDLER, AZ 85225 - UNITED STATES OF AMERICA

is in accordance with the requirements of the following standard

**ISO 14001:2015**  
(Environmental Management System)

**SCOPE**

1. Trading of Oil Products & Crude Oil
2. General Trading
3. Onshore & Offshore Oil & Gas Fields and Facilities Services
4. Logistics & L&M Support
5. Supply of Industrial Equipment to Oil, Gas, Water and Electrical
6. Oil & Gas Storage Tank - EPC
7. Pipe Line Projects EPC
8. Trading of Marine Equipment Oil Vessel, Offshore Platforms & Jack Up Barges
9. Degrassing Stations - EPC
10. Steel Structure Fabrication
11. Supply Security Equipment, Security Services
12. Air Services
13. Commercial Agency

Certificate Number : 22112/0102 Initial Registration Date : 22-Nov-2022  
1<sup>st</sup> Surveillance Date : 22-Oct-2023  
2<sup>nd</sup> Surveillance Date : 22-Oct-2024  
Certificate Expiry Date : 21-Nov-2025

To verify certificate, visit at:  
[www.arscert.com](https://www.arscert.com)  
<https://uafa.com/certification.org>  
<https://www.lafcertsearch.org/>

Issued by ARS Assessment Private Limited  
Managing Director 



UAF Address : 100, North Capitol Dr., STE 202, Norfolk, VA 23502, United States of America.  
This certificate is issued by ARS Assessment Private Limited on behalf of the authority. Validity of the certificate is subject to successful completion of surveillance audits. Renewal of the certificate is subject to the conditions of the registration agreement.





# Industries We Serve



**OIL AND GAS**



**PETROCHEMICAL**



**WATERWORKS**



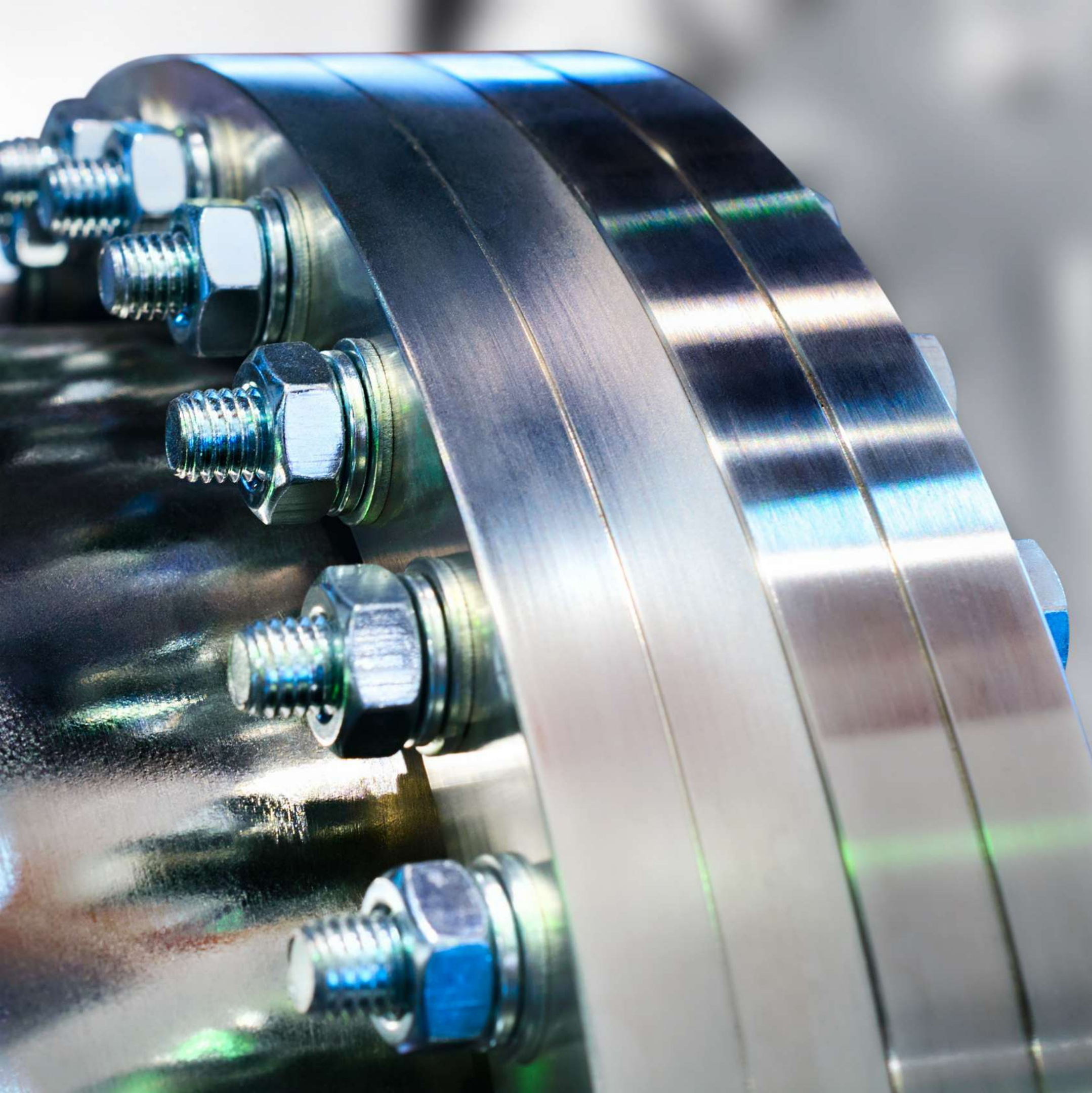

- **FLANGES**
- **ELBOW**
- **STUD**
- **REDUCER**
- **METALLIC GASKET**
- **PIPE FITTINGS**



# Pipe Fittings & Flanges OEM Service



UCG Energy specializes in manufacturing & exporting carbon steel pipe fittings and flanges.

The professional manufacturing capacity of UCG FITTINGS strongly guarantees the high quality, competitive price and short delivery time. UCG FITTINGS has have accumulated rich experience and good reputation in years of serving customers, which making us a reliable pipe fittings & flange supplier to clients from countries over the world. Clients of UCG FITTINGS are mainly from Russia, UAE, Saudi Arabia, Iraq, Iran, Kuwait, Oman, Thailand, Vietnam, South Africa, Nigeria, Chile, Brazil, Canada, Australia, Poland, Lithuania, etc. more than 40 countries.

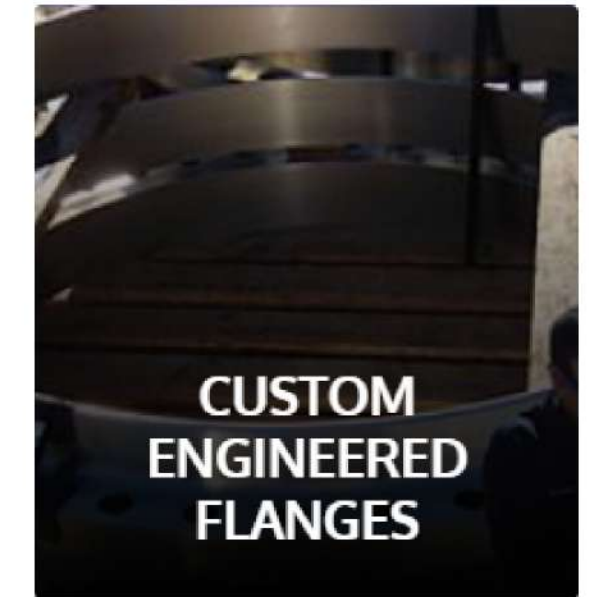
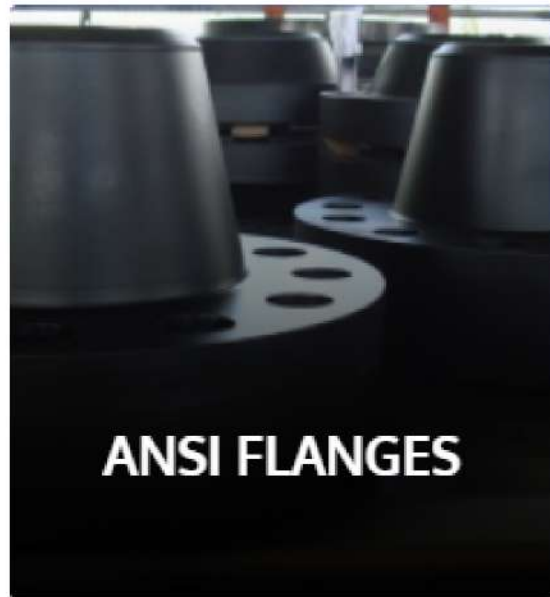



# ANSI - Flanges



ANSI B16.5 Class 150 Flanges



ANSI B16.5 Class 300 Flanges



ANSI B16.5 Class 400 Flanges



ANSI B16.5 Class 600 Flanges



ANSI B16.5 Class 1500 Flanges



# ANSI - ASTM - Elbow





We are Global Manufacturers, Stockist, and Exporters of High Quality Standard Nickel Alloy 200 ASME B16.9 Elbow, ASTM A403 SS ASME B16.9 Elbow, ANSI B16.9 Elbow, Monel Buttweld ANSI B16.9 Elbow, 304 SS ASME B16.9 Elbow, Stainless Steel ASME B16.9 Elbow, Buttweld ANSI B16.9 Elbow Fittings, Alloy Steel ASME B16.9 Elbow, Butt weld ANSI B16.9 Elbow, Duplex Steel ASME B16.9 Elbow Fittings, ANSI B16.9 Elbow available in all dimensions.





# ANSI - Metallic Gasket



	<ul style="list-style-type: none"><li>• <b>Spiral Wound Gasket</b><ul style="list-style-type: none"><li>◦ Gasket - SW, ANSI CI <b>150</b>, B16.5, ASME B16.20 (in)</li><li>◦ Gasket - SW, ANSI CI <b>300</b>, B16.5, ASME B16.20 (in)</li><li>◦ Gasket - SW, ANSI CI <b>400</b>, B16.5, ASME B16.20 (in)</li><li>◦ Gasket - SW, ANSI CI <b>600</b>, B16.5, ASME B16.20 (in)</li><li>◦ Gasket - SW, ANSI CI <b>900</b>, B16.5, ASME B16.20 (in)</li><li>◦ Gasket - SW, ANSI CI <b>1500</b>, B16.5, ASME B16.20 (in)</li><li>◦ Gasket - SW, ANSI CI <b>2500</b>, B16.5, ASME B16.20 (in)</li></ul></li></ul>		<ul style="list-style-type: none"><li>• <b>Ring Type Joint Gasket</b><ul style="list-style-type: none"><li>◦ Gasket - RTJ, ANSI CI <b>150-2500</b>, ASME B16.20, Ring Numbers (in)</li><li>◦ Gasket - RTJ, ANSI CI <b>150-2500</b>, ASME B16.20, Ring Dimensions (in)</li></ul></li></ul>
	<ul style="list-style-type: none"><li>• <b>Full Face Gasket</b><ul style="list-style-type: none"><li>◦ Gasket - FF, ANSI CI <b>125/150</b>, ASME B16.21 (in)</li><li>◦ Gasket - FF, ANSI CI <b>250/300</b>, ASME B16.21 (in)</li></ul></li></ul>		<ul style="list-style-type: none"><li>• <b>Ring Type Gasket</b><ul style="list-style-type: none"><li>◦ Gasket - RT, ANSI CI <b>125/150</b>, ASME B16.21 (in)</li><li>◦ Gasket - RT, ANSI CI <b>250/300</b>, ASME B16.21 (in)</li></ul></li></ul>



# ANSI - Metallic Gasket



## HIGH STRENGTH STRUCTURAL BOLTS Dimensions of Heavy Hex Structural Bolts

Nominal Size or Basic Product Diameter	E		F			G		H			R		L <sub>T</sub>	Y	Runout of Bearing Surface FIM	
	Body Diameter		Width Across Flats			Width Across Corners		Height			Radius of Fillet		Thread Length	Transi- tion Thread Length		
	Max	Min	Basic	Max	Min	Max	Min	Basic	Max	Min	Max	Min	Basic	Max		
1/2	0.5000	0.515	0.482	7/8	0.875	0.850	1.010	0.969	5/16	0.323	0.302	0.031	0.009	1.00	0.19	0.016
5/8	0.6250	0.642	0.605	1-1/16	1.062	1.031	1.227	1.175	25/64	0.403	0.378	0.062	0.021	1.25	0.22	0.019
3/4	0.7500	0.768	0.729	1-1/4	1.250	1.212	1.443	1.383	15/32	0.483	0.455	0.062	0.021	1.38	0.25	0.022
7/8	0.8750	0.895	0.852	1-7/16	1.438	1.394	1.660	1.589	35/64	0.563	0.531	0.062	0.031	1.50	0.28	0.025
1	1.0000	1.022	0.976	1-5/8	1.625	1.575	1.876	1.796	39/64	0.627	0.591	0.093	0.062	1.75	0.31	0.028
1-1/8	1.1250	1.149	1.098	1-13/16	1.812	1.756	2.093	2.002	11/16	0.718	0.658	0.093	0.062	2.00	0.34	0.032
1-1/4	1.2500	1.277	1.223	2	2.000	1.938	2.309	2.209	25/32	0.813	0.749	0.093	0.062	2.00	0.38	0.035
1-3/8	1.3750	1.404	1.345	2-3/16	2.188	2.119	2.526	2.416	27/32	0.878	0.810	0.093	0.062	2.25	0.44	0.038
1-1/2	1.5000	1.531	1.470	2-3/8	2.375	2.300	2.742	2.622	15/16	0.974	0.902	0.093	0.062	2.25	0.44	0.041



Studs:

Material & Mechanical Properties: ASTM A193 Grade B7

Threads: ASME B1.1, UNC or UN8, Class 2A

Nuts:

Material & Mechanical Properties: ASTM A194 Grade 2H

Dimensions: ASME B18.2.2

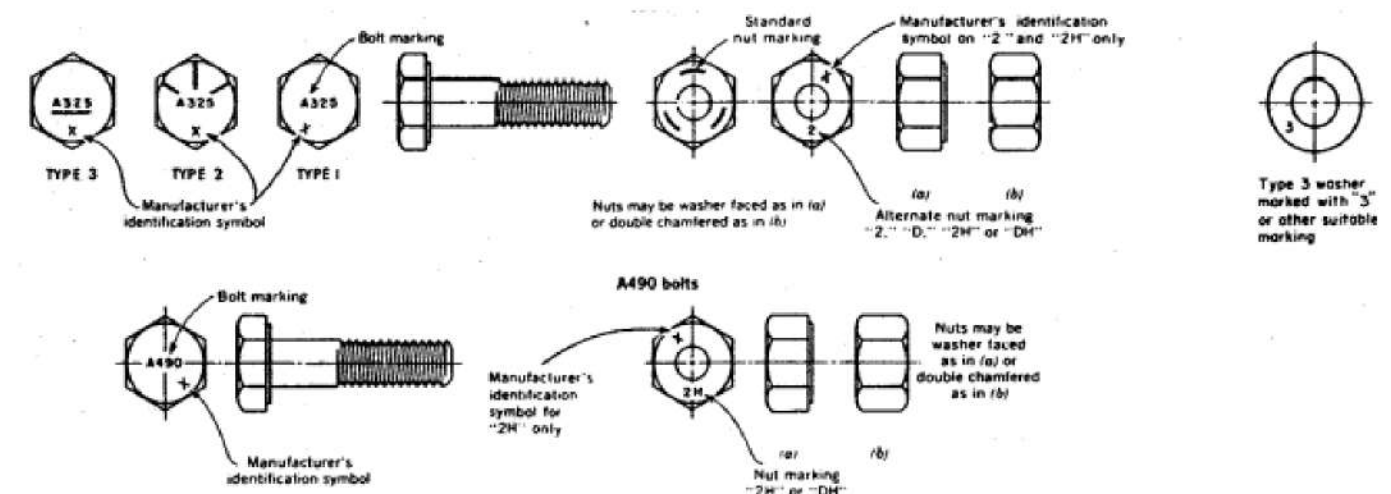



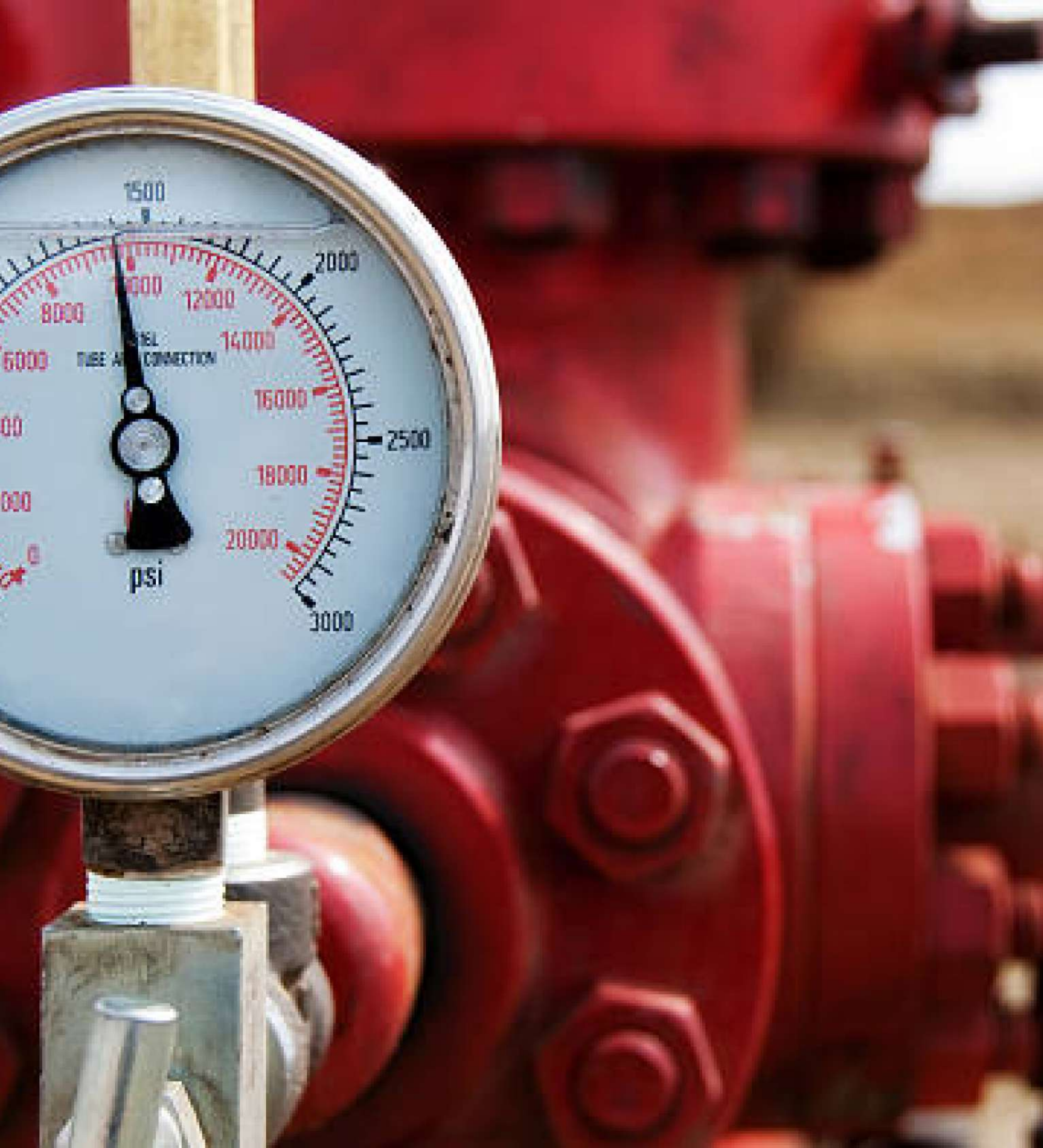

- **API 6A Valves**
- **Wellhead Equipment**
- **Christmas Tree**
- **Manifold**
- **Wellhead Components**
- **API 6A Components**
- **Blowout Prevention System**
- **Multiport Selector Valve**  
**Manifold**
- **Flowback Equipment & System**
- **Sand Management Solutions**
- **Hydraulic Systems**
- **H2S Removal Equipment**





# Well Head Equipments



United Capital Group Energy L.L.C., USA is a engineering and manufacturing company based in America. We designs, fabricates, and supplies wide variety of equipment, such as wellhead assembly, Christmas tree, blowout preventers, choke manifolds, kill manifolds, wellhead desander, plug catchers, high-pressure API 6A valves, emergency shutdown valves and ESD system, high-pressure pipe & fittings.



**Casing Head Housing**



**Tubing Head Adapter**



**API 6A Check Valves**



**Surface Test Tree**



**Christmas Tree**



**Kill Manifold**



**Choke manifold**



**Well Control System Equipment**





- **POWER TRANSFORMER**
- **SPECIALIZED TRANSFORMER**
- **DISTRIBUTION KIOSK TRANSFORMER**
- **ELECTRICAL INDUSTRY GRADE PANELS**
- **RESISTORS**
- **SPARE PARTS**
- **RMU**
- **SWITCH GEARS**
- **OIL IMMERSED TRANSFORMER**



# Transformers



United Capital Group Energy L.L.C., USA offers a complete chain of services – from consulting to design, manufacture and transport to commissioning and Transformer Lifecycle Management (TLM). As one of the leading transformer manufacturers worldwide, we offer a tight and responsive competence and service network in more than 30 countries in the world.



**Power generation**



**Unit auxiliary transformer**



**System-interconnecting transformer in high-voltage substations**



**Plant-feeding transformers for industrial applications**



# Transformers - Ranges



**SOLAR INVERTER DUTY TRANSFORMER**



**CAPACITY: UP TO 8 MVA**

**TRANSFORMER WITH BUILT IN A.V.R  
(HT A.V.R)**



**CAPACITY: UP TO 20 MVA**

**TRANSFORMER WITH OLTC (ON LOAD TAP CHANGER)**



**CAPACITY: UP TO 31.5 MVA**



# Transformers - Ranges



**VPI DRY TYPE TRANSFORMER WITH OLTC**



**CAPACITY: UP TO 5MVA**

**VPI DRY TYPE DISTRIBUTION TRANSFORMER**



**CAPACITY: UP TO 5MVA**

**DISTRIBUTION TRANSFORMER  
UP TO 33 KV CLASS**

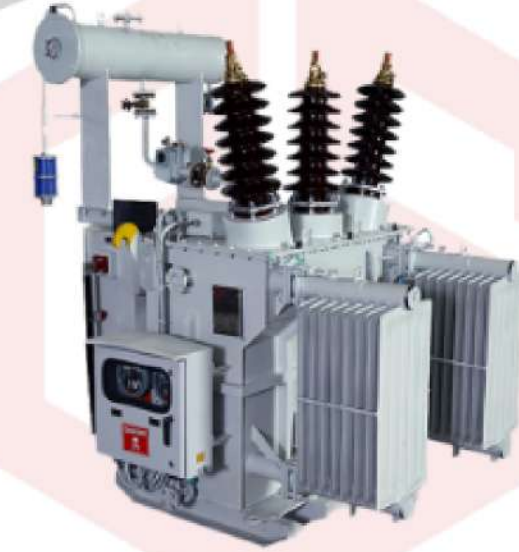

**CAPACITY: UP TO 5 MVA**





- **SHUT-OFF VALVE TEST UNITS**
- **ENGINEERING & REPAIR**
- **SAFETY VALVE TEST UNIT**
- **CONTROL MEASUREMENTS**
- **PSV TESTING**
- **ACCESSORIES**



# Shut-Off Valve Test Units



United Capital Group Energy L.L.C., USA offers a large variety of machines and equipment for the repair and testing of any valve type, size and pressure class. Our mission is to supply guidance by sharing our experience. To pioneer, innovate and manufacture first class test and repair equipment for valves. We deliver safety.

The design and configuration of the UCG products are well proven and based on many years of experience in Shut-off valve, Safety valve and Control valve maintenance, testing and repair. The Ventil equipment is fully built in-house and only first class and durable materials are used. Most machines are available from stock at one of the UCG locations across the globe.





# Shut-Off Valves Units



MODEL: VCB30

- ⊕ Vertical clamping and testing of all common valves.
- ⊕ Available up to 120" / DN 3,000 mm with clamping force up to 5,000 ton.
- ⊕ Up to 200 ton with rotating bridge, larger models with rail system for quick and safe (un)loading.

Model	Range*	Maximum clamping force	Distance between columns	Distance between sealing adapters	Low pressure Gas test system	High pressure Liquid test system
VCB5	½ - 6" DN15 - 150 mm	5 ton	14" 350 mm	0 - 20" 0 - 500 mm	0 - 7 bar / 100 PSI  Other Gas test systems up to 1,000 bar / 14,500 PSI available on request.	0 - 400 bar / 5,800 PSI  Other Liquid test systems up to 2,500 bar / 36,250 PSI available on request.
VCB30-S	½ - 10" DN15 - 250 mm	30 ton	18" 460 mm	0 - 30" 0 - 750 mm		
VCB30-L	½ - 16" DN15 - 400 mm	30 ton	28" 720 mm	0 - 40" 0 - 1,000 mm		
VCB50	1 - 16" DN25 - 400 mm	50 ton	28" 720 mm	0 - 40" 0 - 1,000 mm		
VCB100	2 - 24" DN50 - 600 mm	100 ton	40" 1,000 mm	0 - 44" 0 - 1,100 mm		
VCB200	2 - 36" DN50 - 900 mm	200 ton	55" 1,400 mm	0 - 60" 0 - 1,500 mm		
VCB500	2 - 48" DN50 - 1,600 mm	500 ton	64" 1,600 mm	0 - 60" 0 - 1,500 mm		



# Shut-Off Valve Units



MODEL: HCT3000

Model	Range*	Maximum clamping force	Distance between columns	Distance between sealing adapters	Low pressure Gas test system	High pressure Liquid test system
HC5	½ - 6" DN15 - 150 mm	5 ton	14" 350 mm	0 - 20" 0 - 500 mm	0 - 7 bar / 100 PSI  Other Gas test systems up to 1,000 bar / 14,500 PSI available on request	0 - 400 bar / 5,800 PSI  Other Liquid test systems up to 2,500 bar / 36,250 PSI available on request
HC30-S	½ - 10" DN15 - 250 mm	30 ton	18" 460 mm	0 - 30" 0 - 750 mm		
HC30-L	½ - 16" DN15 - 400 mm	30 ton	28" 720 mm	0 - 40" 0 - 1,000 mm		
HC50-S	1 - 10" DN25 - 250 mm	50 ton	18" 460 mm	0 - 30" 0 - 750 mm		
HC50-L	½ - 16" DN15 - 400 mm	50 ton	28" 720 mm	0 - 40" 0 - 1,000 mm		
HC75	1 - 16" DN25 - 400 mm	75 ton	28" 720 mm	0 - 40" 0 - 1,000 mm		
HC100	2 - 24" DN50 - 600 mm	100 ton	40" 1,000 mm	0 - 44" 0 - 1,100 mm		
HC150	2 - 24" DN50 - 600 mm	150 ton	40" 1,000 mm	0 - 60" 0 - 1,500 mm		
HC250	2 - 24" DN50 - 600 mm	250 ton	40" 1,000 mm	0 - 60" 0 - 1,500 mm		
HC400	2 - 32" DN50 - 800 mm	400 ton	48" 1,200 mm	0 - 67" 0 - 1,700 mm		
HC600-S	4 - 24" DN100 - 600 mm	600 ton	48" 1,200 mm	0 - 67" 0 - 1,700 mm		
HC600-L	4 - 36" DN100 - 900 mm	600 ton	56" 1,400 mm	0 - 80" 0 - 2,000 mm		
HC800	4 - 36" DN100 - 900 mm	800 ton	55" 1,400 mm	0 - 80" 0 - 2,000 mm		
HC1000	8 - 40" DN200 - 1,000 mm	1,000 ton	64" 1,600 mm	0 - 80" 0 - 2,000 mm		
HC1500	8 - 40" DN200 - 1,000 mm	1,500 ton	64" 1,600 mm	0 - 80" 0 - 2,000 mm		
HC2000	8 - 48" DN200 - 1,200 mm	2,000 ton	80" 2,000 mm	0 - 100" 0 - 2,500 mm		
HC3000	8 - 48" DN200 - 1,200 mm	3,000 ton	80" 2,000 mm	0 - 100" 0 - 2,500 mm		
HC4000	8 - 48" DN200 - 1,200 mm	4,000 ton	80" 2,000 mm	0 - 100" 0 - 2,500 mm		

\*The range and dimensions can be adapted to the specific application.





- **PALLET RACKING**
- **CANTILEVER RACKING**
- **DRIVE IN RACK**
- **RADIO SHUTTLE RACKING**
- **HEAVY DUTY RACKS**
- **MEZZANINE RACKS**





# Warehouse Racks

UCG has been developing warehouse racking technologies for many years, and we have a rich variety of racking equipment to meet your customized needs.

No matter you are a racking dealer or an end-user, you can all customize your racking exclusive designs.

We can help you come true the below idea:

- Make your exclusive logo at racking surface
- Your face design and use UCG Storage regular industrial racking section.
- Your full racking design with your section.
- Your other special racking exclusive design.

In order to help you save developing cost and time, we invented an exclusive new design of leading rivals – 3D selective pallet racking sample, we can submit you 1:1 3D sample before bulk production.





# Warehouse Racking



Pallet Racking



Drive In Rack



Radio Shuttle Racking



Gravity Flow Racks



Cantilever Rack



Mezzanine Floor





- **INDUSTRIAL PUMP**
- **OIL & GAS PUMP**
- **MARINE PUMP**
- **RELIEF PUMP**
- **PUMP CONSULTATION**



# Industrial Grade Pump



UCG Energy is a company manufacturing & marketing pumps, process equipment and installations. The production facility is located in America.

The pumps manufactured by us include Progressive Cavity Pumps, Twin Screw Pumps, Triple Screw Pumps, Gear Pumps, Lobe Pumps, Vane Pumps, Shuttle Block Pumps as well as Thermic Fluid Pumps. With this complete range of pumps, Pumpsquare offers to the engineers, suppliers, OEM's and users a single source of supply for their pump requirements.





# Industrial Pumps



Horizontal Foot Mounted Pump Coupled with Geared Motor



Vertical Flange Mounted Pump Directly Coupled with Motor



Pump with Built-in Relief Valve with facilitation of connection to tank for preventing overheating of pumping media



Pump with Line Mounted Relief Valve



# Twin Screw Pump



## Series Features:

Capacity Range: up to 550 m<sup>3</sup>/hr

Viscosity Range: up to 207600 cSt

Temperature Range: up to 80° C

Pressure Range: up to 16 Bar

As the double-start screws meshes, a continuous axially moving voids/pockets generate, which traps the liquid inside it, and hence transfers the fluid, where it required.

These pumps permits an even axial flow without pulsation and silent pumping operation even at a high speed. Axial loads on the rotor are often compensated by an adequate design of the bearing and all the radial forces are self-compensated.

Further, size of a rotor kept small in the design, which enables these pumps to run at a higher speed with direct coupling to the prime mover. Self-compensated radial forces eliminate need of bearing High pressure capacity up to 40 Bar Self-Priming and reversible cartridge design simplifies maintenance problem and saves lead time.

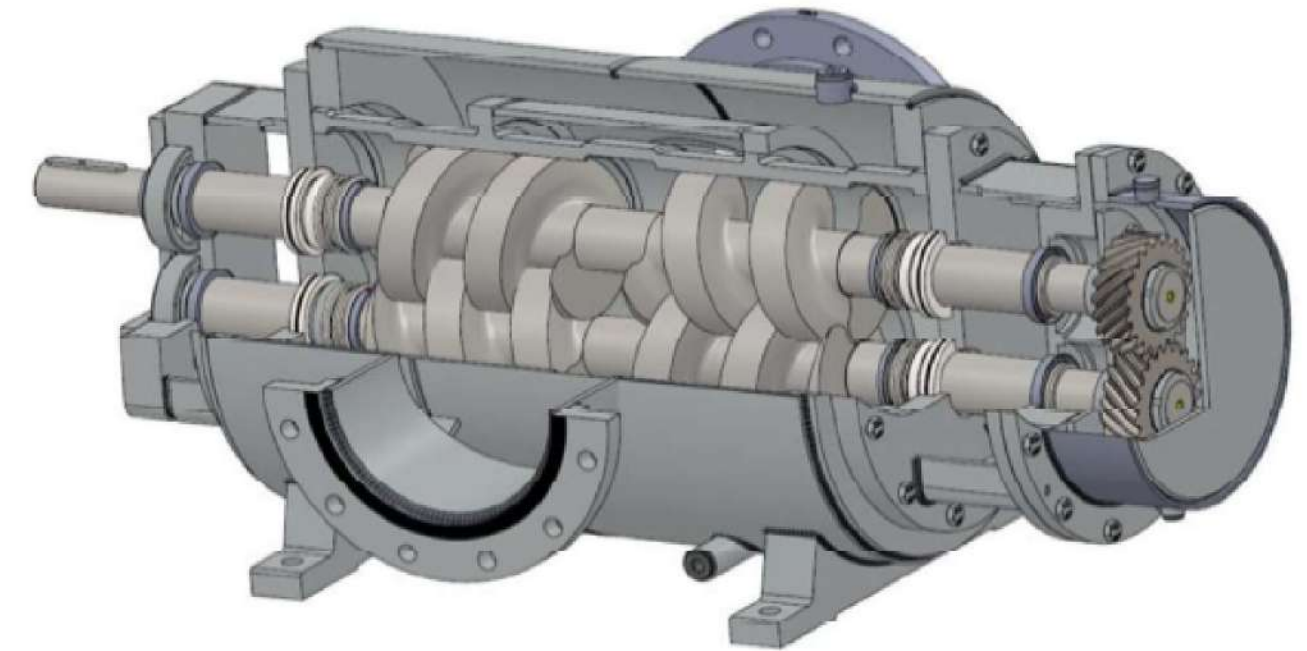

As shown in the above figure, the API version of pump can be provided on demand, which incorporates timing gears on back side. Further, helical timing gears are also provided when requested. Please note that our standard design contains spur timing gears on front side.





# Connect with us.

Email

[Info@ucgenenergy.us](mailto:Info@ucgenenergy.us)

Address:

**4535 E Amberwood Dr, Phoenix, AZ  
85048 USA**

Website:

[www.ucenergy.us](http://www.ucenergy.us)

