



**UNITED CAPITAL GROUP ENERGY L.L.C., USA**

An International Integrated Oil & Gas EPC Company

DUNS No.: 117680347 | CAGE Code: 8QW55 | JCCS No.: 117288 | Registered in SAM

Your service partner for life.



**Triveni**  
TURBINES



**PARTS  
& SERVICE**





# Contents

Power of performance	02
Our Offerings	03
Excellence is our DNA	04
Predictive & Preventive Maintenance	06
LTSA / AMC	06
Troubleshooting & Health checkup	07
Value Addition Service Solutions	08
Comprehensive O&M services	10
Turnkey Solutions	10
Remote Monitoring & Diagnostic Solution	11
Balance of Plant	12
Research & Development	12
High Speed Balancing	13
Knowledge Empowerment	14
Manufacturing Excellence	15
Industries We Serve	16
Our Global Presence	17

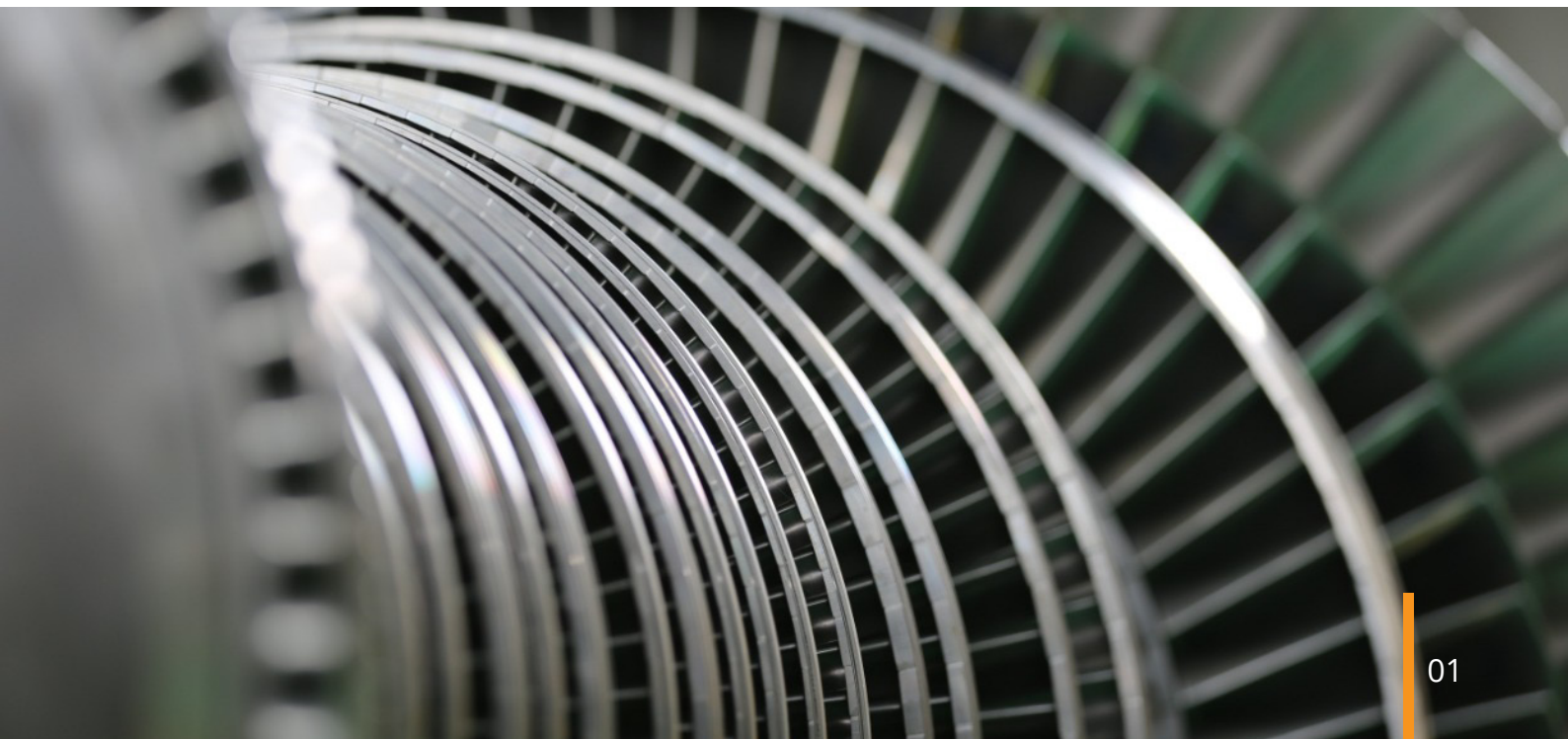



# Power of Performance

We stand by incorporating technology and services as our key differentiator and tool to deliver growth thus maintaining our position as leaders in steam turbines. We at Triveni Turbine Ltd., present comprehensive turbine maintenance solutions that will ensure smooth functioning of your plant for a long time.

 **13000+ MWe**  
Global Installed Capacity

 **Focus on customer satisfaction**

 **4000+**  
Steam Turbines Installed

 **50%** Market Share in our segment

 **200+**  
Annual Turbines Manufacturing Capacity

 **24X 7**  
Service Support

 **Active service support to all operational turbines**



## Your trusted partner

Triveni's assurance of complete life cycle support for Turbine-generator island:

- ❖ Supply of turbo generator set
- ❖ Erection & commissioning of the turbo generator
- ❖ Performance test of the turbo generator
- ❖ After sales service support for complete life cycle of turbine generator island
- ❖ Long Term Service Agreement for Turbo Generators
- ❖ Operation and maintenance services
- ❖ Refurbishment for performance restoration and upgradation
- ❖ Upgrades, De-rating based on customer requirements
- ❖ Turnkey solutions for all kinds of Overhauling, modifications all over the globe





# Our Offerings

We offer quick response in the delivery of spares and follow best practices to control spare parts inventories. Our advantages include:



**Predictive & Preventive Maintenance**



**Remote Monitoring & Diagnostic Solutions**



**Troubleshooting & Health check-up**



**Automation & Modification**



**Efficiency Improvement & Restoration**



**Balance of Plant Solutions**



**Upgrade & Derates**



**Turnkey Solutions**



**O & M Services**



**High Speed Balancing**



**LTSA/AMC**



**Training Programs**



**Steam Turbine**



**Controls**



**Generator**



**Oil Console**



**Condensor**



**Balance of Plant**

# Excellence is our DNA

- ❖ Commissioning spares
- ❖ Recommended spares
- ❖ Predictive spares
- ❖ Conditional spares
- ❖ Capital spares
- ❖ Balance of plant spares



Highest Quality Service

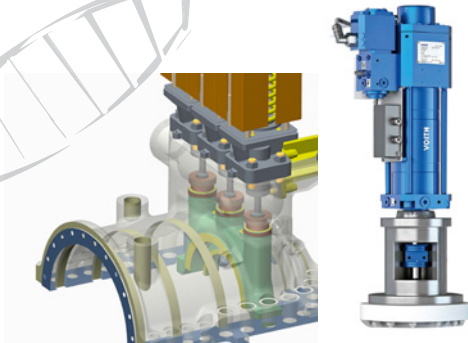

Governing System

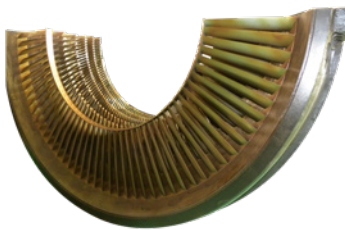
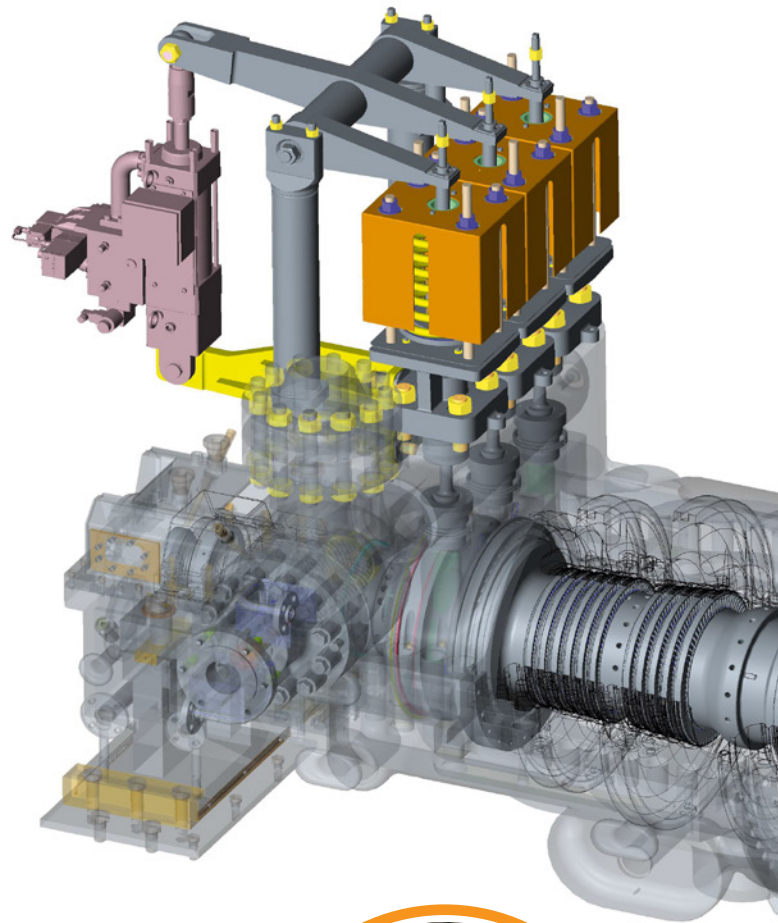

Blade Carrier

Mechanical Run Test Facility



State of Art Manufacturing Facilities





**R&D to Support latest Advanced Technology**

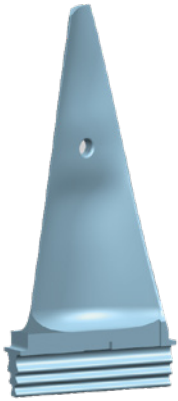

**Redesign & Replacement With Higher Efficiency Blades**

**Rotor Replacement, Modification & High Speed Balancing**



**Redesign Of Steam Flow Path**

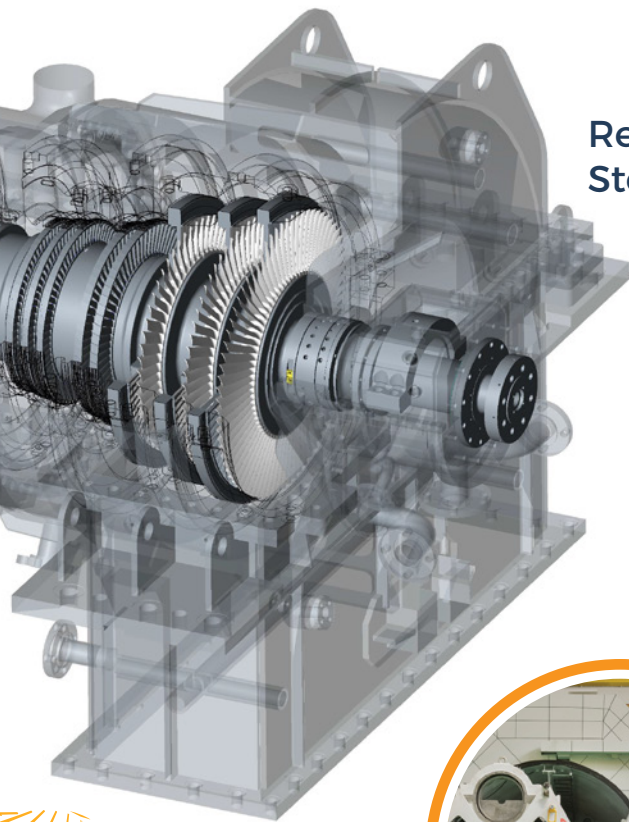

**Supply Of Critical Spare Parts**



**High Speed Balancing Vacuum Tunnel for all kinds of Rotors**



# Predictive & Preventive Maintenance

Intelligent maintenance predicts the future and boost availability of TG Set through predictive and preventive measures. Predictive and preventive maintenance intelligence on the health of turbine can reduce scheduled and unscheduled downtime, driving down maintenance costs and increasing safety and availability. Timely Implementation of Major and Minor Overhauling helps you to avoid unplanned downtime and to make the most of hidden potential through continuous optimization, thereby improving your competitiveness over the long term.

## AMC / LTSA (Long Term Service Agreement)

We have in our portfolio a very powerful AMC program. This gives the comfort and confidence to the customer of an extended period under the Triveni umbrella. This customized package is formulated to proactively deploy our service team and support the customer during both normal as well as emergency service requirement.

Our AMC offers includes services as per customized manday basis which covers:

- ❖ Major Overhauling
- ❖ Minor Overhauling
- ❖ Health Check up Visits
- ❖ Troubleshooting Visits



# Troubleshooting & Health checkup

---

We stand by creating value and delight for our customers by incorporating technology and services as our key differentiator to deliver growth.

## Troubleshooting

There is nothing more expensive than losing production. We offer quick support to depute our highly skilled engineers to troubleshoot the problem in addition to analyze the root cause and recommend remedial to minimize downtime. Triveni is committed to help you 24\*7 to maintain and safeguard your assets over their entire lifecycle.

Being an OEM, we know our machine better than anyone. With the experience of more than 4000 installation globally and expertise workforce , we analyze and solves the problem quickly and effectively to guarantee maximum availability of the machine.

## Regular Health Checkup

Gain valuable uptime through our regular Health Checkup visits which ensures you many years of peace of mind from emergency breakdowns. Health checkup visits by our highly skilled engineers helps you to identify problems proactively and support you in planning preventive maintenance to upkeep turbine efficiency and reliability.



# Value Addition Packages

## Upgradation Packages & Conversion Packages

Even after many years of faultless service, machine can become less efficient. Also, with continuous R&D on various aspects of turbine design, the old designs become redundant. With our modernization & efficiency improvement packages, to yield greater efficiency.

Different value addition solutions includes:

- ❖ Efficiency Improvement & Restoration
- ❖ Change in Operating Parameters
- ❖ Derate Solutions
- ❖ Power Enhancement Solutions
- ❖ Conversion of condensing turbines to Back Pressure
- ❖ Water Cooled to Air Cool & Vice Versa
- ❖ Modernization packages for simpler operation & added reliability
- ❖ Governor retrofit

### Customer benefits:

- ❖ Lower specific steam consumption
- ❖ Meeting new requirements
- ❖ Fresh life into the machine
- ❖ Enhanced safety & protection

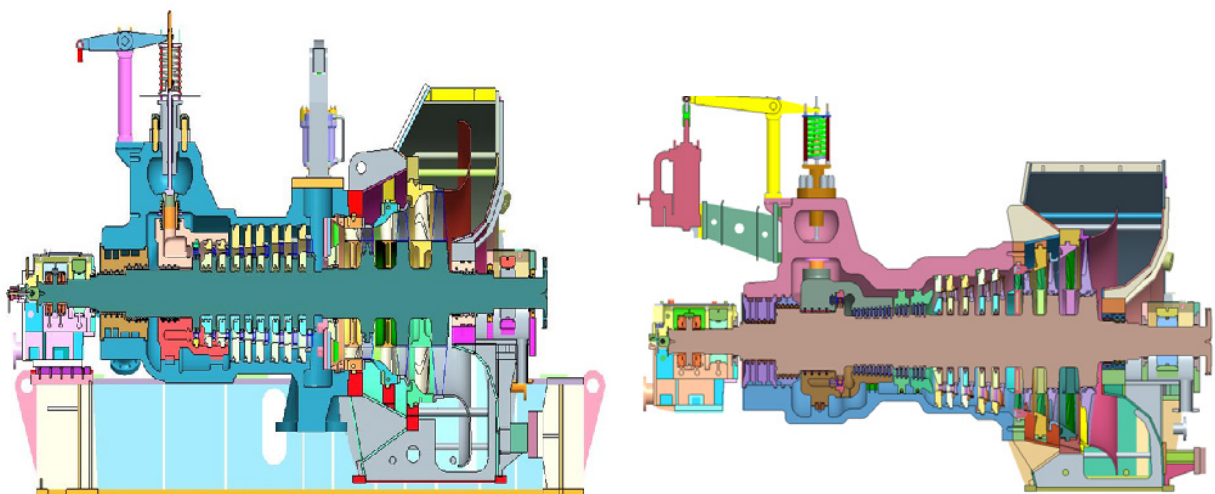
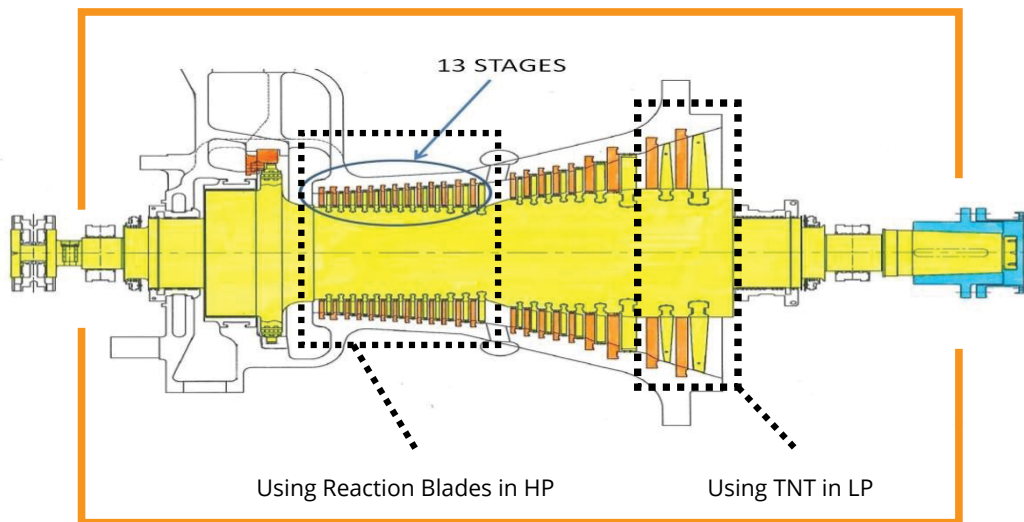



# Value Addition Packages

## Automation & Electrical Modification

Embracing new technology protects the value of your ageing assets and minimizes capital expenditures. Automation and upgradation enhances reliability and performance of your turbine and its system. We support our customer to modernize their aging technology to a better solution optimizes productivity and response of machine. Our automation and electrical modification packages include:

- ❖ Turbine Automation
- ❖ Vibration Monitoring System
- ❖ Load Management System
- ❖ Exhaust Hood Spray System
- ❖ Governor Retrofitting
- ❖ Grid synchronization Solution
- ❖ PLC/DCS panel implementation
- ❖ Auto Gland Sealing System

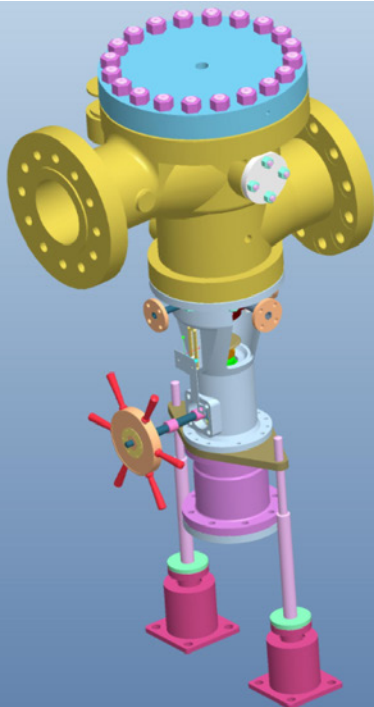
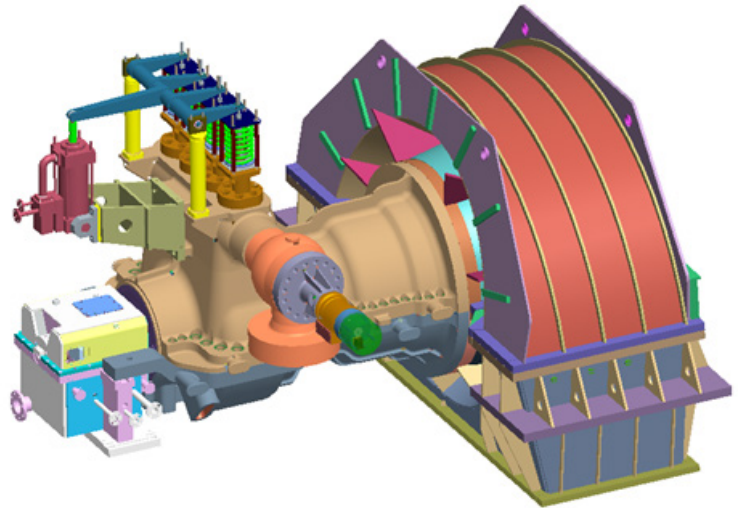
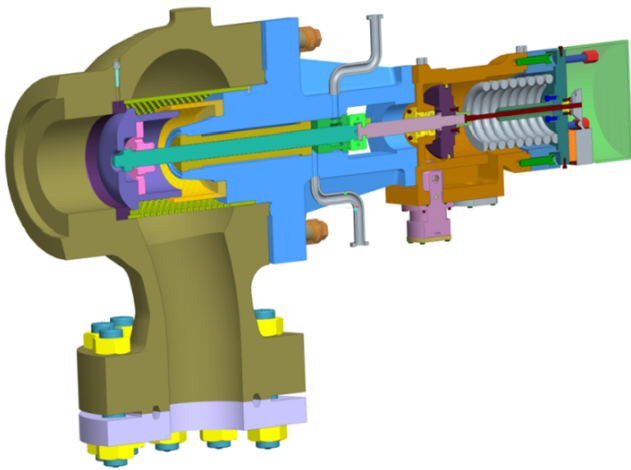

Manual Operation



Auto Operation



## Comprehensive O&M services

We have over five decades of experience thus you can depend on us to provide complete plant services across the turbine island and balance of plant for both Triveni and Non-Triveni equipment.

Our O&M services are guided by the specific needs of the customer & take care of their non-core activities. Triveni Turbines works closely with plant developers and owners to identify their goals and create a power plant O&M plan designed to achieve the desired results.

- ❖ Complete plant staffing
- ❖ Report generation and problem identification at site
- ❖ Daily operation and maintenance of the plant
- ❖ Local and remote monitoring and diagnostics
- ❖ Comprehensive training
- ❖ Environmental health and safety programs
- ❖ Site documentation and procedure development
- ❖ Site-specific computerized maintenance management programs
- ❖ Fuel Management

Triveni's O&M programs maintenance services optimize outage internals and schedules, which are backed by performance guarantees to help customer meet their financial expectations.

## Turnkey Solutions

In our Endeavour to provide the best in class customer support, we offer comprehensive turnkey solution for complete maintenance of TG island. As an OEM, with strong manufacturing capabilities and with more 4000 installations globally, we have an undisputed advantage of complete backup of OEM design and engineering support to our frontline engineers to attain maximum reliability of your plant.



# Balance of Plant

Triveni Turbine Ltd, with its immense experience, partners with customers providing them turnkey power solutions through its Balance of Plant (BOP) contracts. This gives the customer a hassle free execution of the entire power plant through a single point contact. Triveni, with its expertise in design and consulting, project execution and supply chain, has executed BOP projects in the India.

Our scope includes (but not limited to) the following:

- ❖ Cooling Tower and related Accessories: Civil and FRP Cooling Tower, Cooling Water Pumps and Systems, Piping, Side Stream Filtration System, Dosing Pumps etc
- ❖ Steam Piping / Cooling Water Piping / Condensate Piping / De-aerator Piping
- ❖ Electrical Systems including Breakers / Transformers / Panels / Cabling / Bus Ducts / Reactor Panels etc.
- ❖ Fire Fighting System Package
- ❖ Civil and Structural works and Services for Power House Buildings, Cable Trenches, Pipe Trestles, Over Head Tanks, Electrical Control Rooms, Switch Gear Room, Pump House, etc.,
- ❖ Handling and hoisting systems - Cranes / Elevators / Hoists / Chain Pulley Blocks.
- ❖ DCS and PLC Systems.
- ❖ Air Cooled Condensers and related accessories
- ❖ Air Compressors Package.

# Research & Development

- ❖ Technology intensive solutions for Biomass, Waste to Energy, Process Cogeneration, API and CSP applications
- ❖ Quick customized solutions from proven standard modular building blocks from regular customer orders
- ❖ State of the art computational tools and expertise in Aero design, Structural Design, Rotor Dynamics, Thermal Design and Control System
- ❖ Extensive design validation from aero cascade tests, in house load test facility, vacuum tunnel, mechanical run test, CFD, FEA and field tests for robust turbomachinery
- ❖ Extensive library of high efficiency HP, IP, LP blade families to suit retrofit solutions
- ❖ Evolving with better sealing designs for minimizing the leakage losses
- ❖ Association with leading design houses in US, IISc, IIT and panel of domain experts with long design and operating experience
- ❖ Continuous upgrade of technology to achieve Capex and Opex advantage to Customer

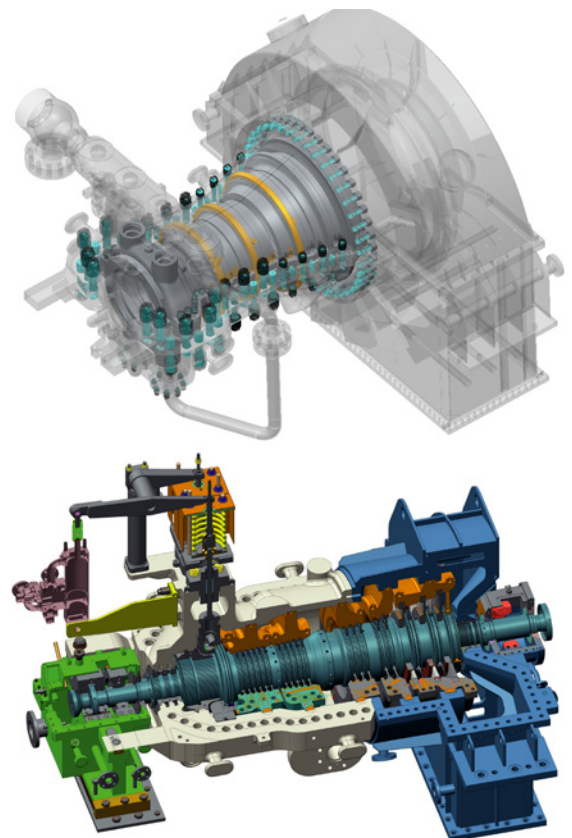

# High Speed Balancing

Our State-of-the-art servicing facility has been strengthened with the high speed balancing machine from SCHENCK Ro Tec Germany for balancing of rotors. This facility is equipped with CAB 920 and CAB Flex++ software to enable highest level of balancing of rotors.

- ❖ Hassle free and silent operation through entire speed range up to over speed
- ❖ The ability to access optimal weight planes, which are not normally accessible during operation in the machine
- ❖ Verification of the mechanical integrity of the rotor and any assembled components—up to over speed
- ❖ Electrical testing of generator rotors through their entire speed range can identify the existence of any speed related electrical faults





# Knowledge Empowerment ( The Learning Center )

---



Our Learning Centre is the fulcrum for all the technical training needs of Triveni Turbines. We have a world-class learning centre to enable continuous learning for our own corporate, design and field service engineers on a variety of subjects including the latest technology offerings and solutions.

We also offer training for our customer staff to share our expert's knowledge and skills helping them to understand and optimize turbine operation and maintenance of TG set and plant performance.

The various programs have been designed in consultation with the various teams in engineering, manufacturing and service team. The standard module provides a Computer Based Training (CBT), class room interactive training and shop floor training. We can also sit with your team custom build training programs for the employees of your company.





# Industries Served

Our steam turbines serve a vast range of industries ranging from Food and Sugar to Biomass and Textiles and beyond. With the mission to provide low-cost, energy-efficient and environment friendly solutions, we invest into extensive research & development leading to world-class industry specific solutions for every client.



Sugar



Oil & Gas



Palm Oil



Barge Mounted IPP



Distillery



Pulp & Paper



Biomass IPP



District Heating



Steel



Carbon Black



Food



Textiles



Chemicals



Municipal Solid Waste-IPP



Cement







**UNITED CAPITAL GROUP ENERGY L.L.C., USA**  
An International Integrated Oil & Gas EPC Company  
DUNS No.: 117680347 | CAGE Code: 8QW55 | JCCS No.: 117288 | Registered in SAM

SCAN FOR  
ENQUIRY

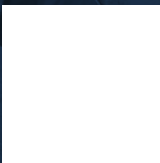

VISIT  
WEBSITE



 [info@ucenergy.us](mailto:info@ucenergy.us)

 [/TriveniRefurb](#)  [/triveni-refurb](#)



**Triveni**  
TURBINES



**PARTS  
& SERVICE**

[www.ucenergy.us](http://www.ucenergy.us)  
[www.triveniturbines.com](http://www.triveniturbines.com)